

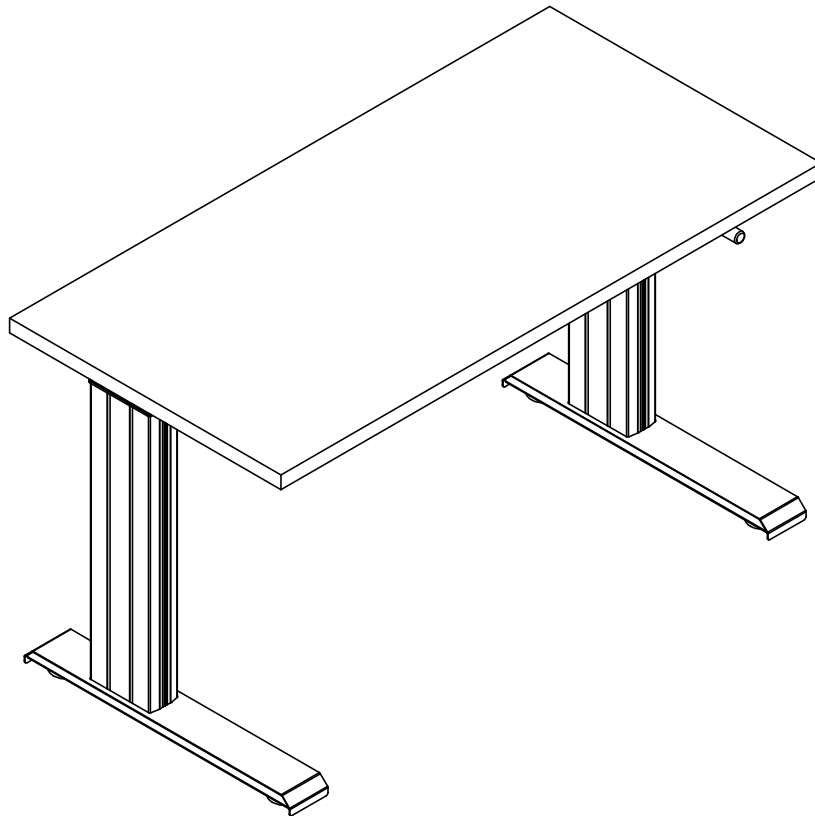

K&A Manufacturing
6703 Zinser Street
Schofield, WI 54476
Phone: 800.298.4351
Fax: 866.882.9475
www.raproducts.com
Version Dated: 8/8/16

NewHeights Series 4 Vuelta Crank Height Adjustable Workstation



Read all the instructions before beginning.

Tools Required for Assembly:
Power Driver W/Adjustable Torque
#2 Phillips Head Driver Bit
#2 Square Head Driver Bit
3/16" Hex Head Driver Bit or
Allen Wrench
Tape Measure
Level



5

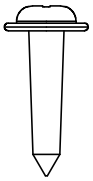

51708

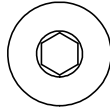

8

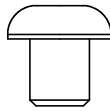

53638

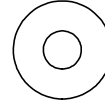

B

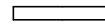

52336



C

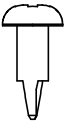

52678

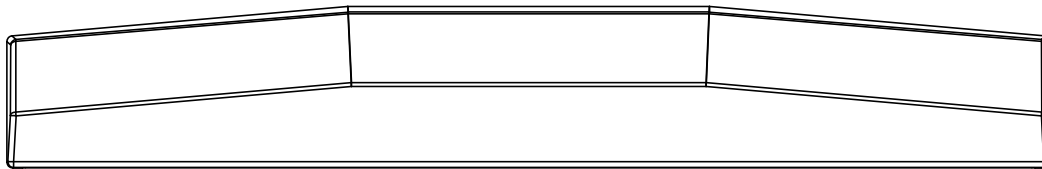

800394

9

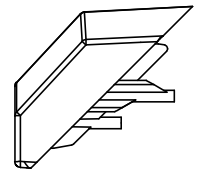

Hardware Pack 53507
Hardware is Drawn Actual Size

Warranty Information: NewHeights™ products are warranted to be free of defects due to manufacturing or materials as follows: Three years on the gears. Five years on the support brackets, aluminum columns and feet. We will replace any defective part after inspection by an authorized agent. Costs incurred due to product replacement such as installation labor and transportation are not covered under this warranty. When corresponding with RightAngle™ products, provide the model and serial numbers located on one of the leg assemblies.

The drawing below shows how to distinguish the left leg A from the right leg B.

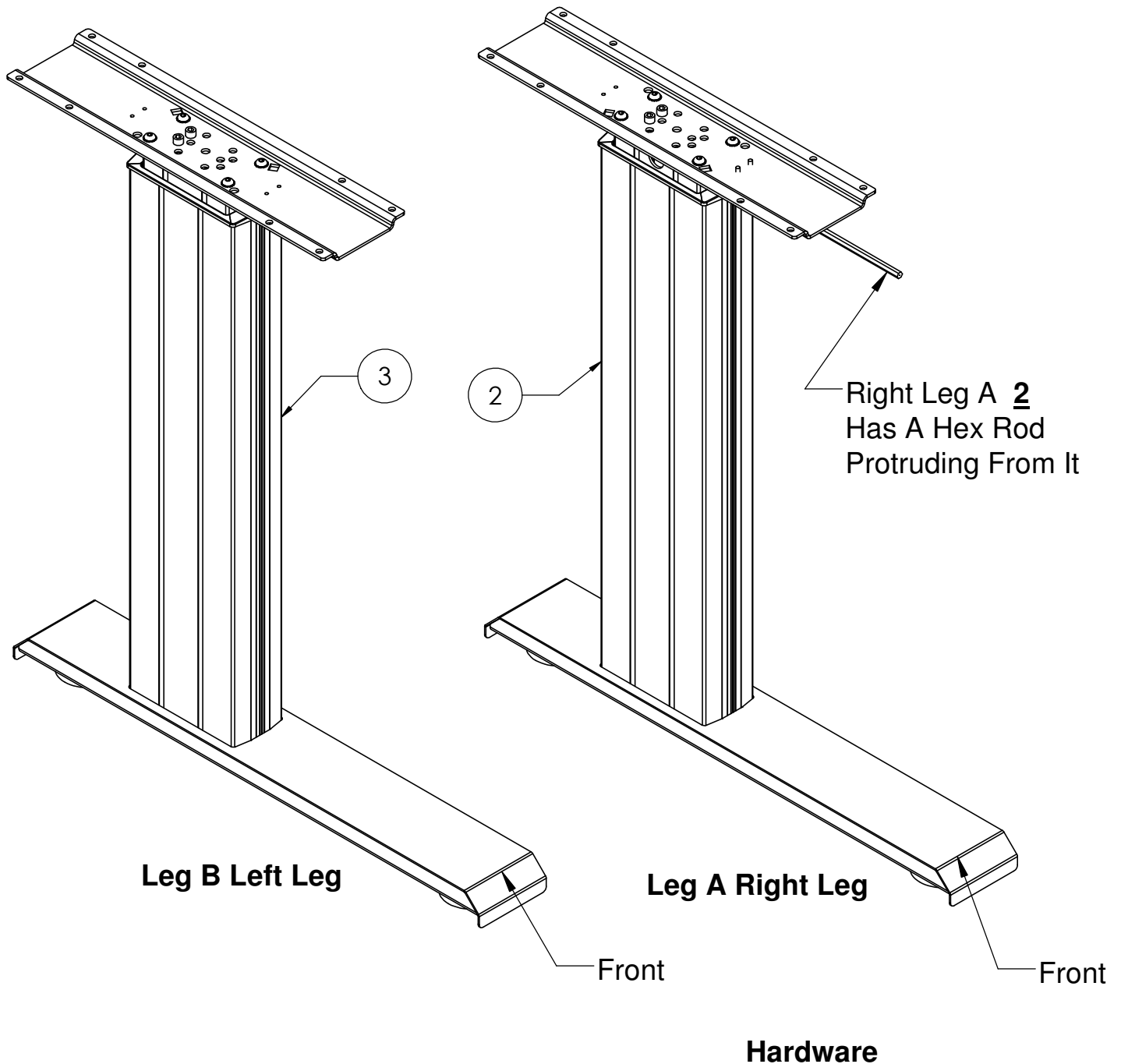

Step 1: Lay the worksurface **1** on a protected surface with the pilot holes facing up. There are metal inserts in the worksurface. These should not be used for this workstation. Place the right leg assembly **2** on the worksurface aligning the holes in the worksurface support with the pilot holes in the worksurface. The

right leg assembly is the one with the hex rod protruding out of the front of the inner column. See Page 2. Attach the leg assembly to the worksurface with (4) wood screws **5** in the outside corners of the worksurface support. Leave the screws loose by about 1/8" until the cross support **6** is installed.

Step 2: Insert the hex rod **4** into the hex drive in the right leg assembly **2** until it bottoms out.

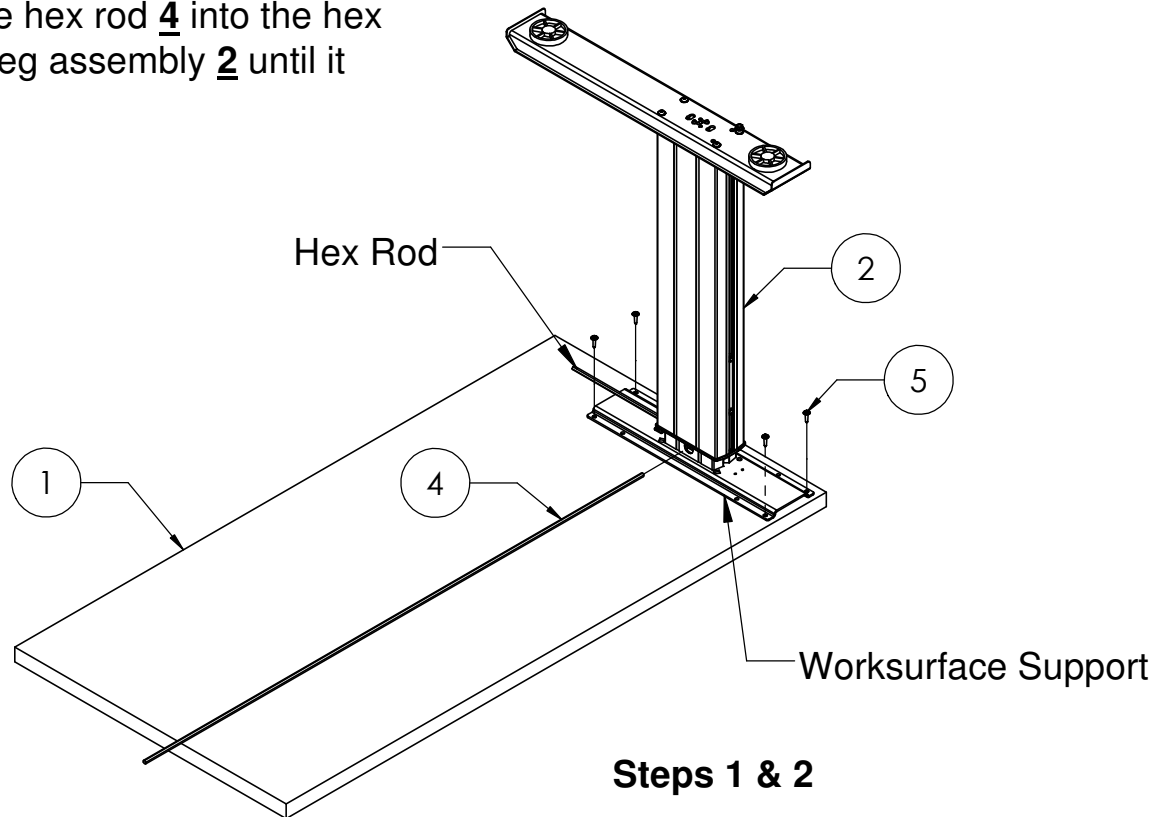

ITEM #	PART #	DESCRIPTION	QTY.
1	Varies	NH S4 Worksurface	1
2	Varies	Crank Leg Assembly A Right	1
3	Varies	Crank Leg Assembly B Left	1
4	Varies	S4 Crank Hex Rod	1
5	51708	M5 x 18mm (7/8") Sq/Ph/Wshr Head Wood Screw	28
6	Varies	Series 4 Cross Support	1
7		Not Used	
8	53638	5/16-18 x 3/8 Button Head Socket Screw	4
9	800934	Cross Support End Cap	2
10	Varies	LT U-Channel	1
11	Varies	S 4 Crank/Bracket/Clamp Assembly	1

Step 3: Place the left leg assembly **3** on the work-
surface **1** inserting the hex rod **4** into the hex drive
near the top of the inner column. Align the pilot holes
on the worksurface support with the pilot holes in the
worksurface. Attach it with (4) wood screws **5** in the
outside corners of the worksurface support. Leave the screws loose by about 1/8" until the
cross support is installed.

Step 4: Align the holes in the u-channel **10** with the pilot holes in the worksurface. Attach
the u-channel with (8) or (10) wood screws **5** . Fully tighten.

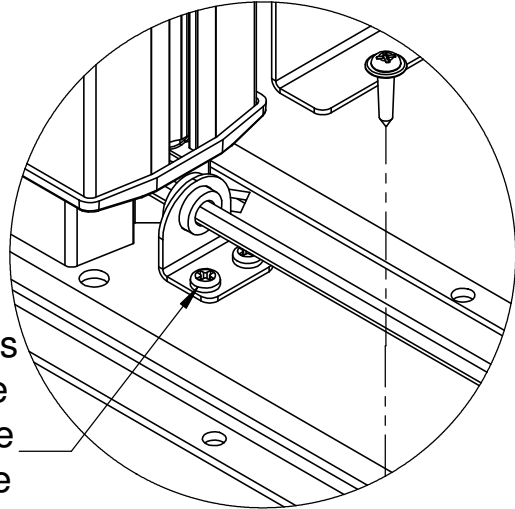

Remove these two screws
if you want to change the
crank to the left hand side
of the table and insert the
hex rod into the front of the
left leg **3** .

Detail A

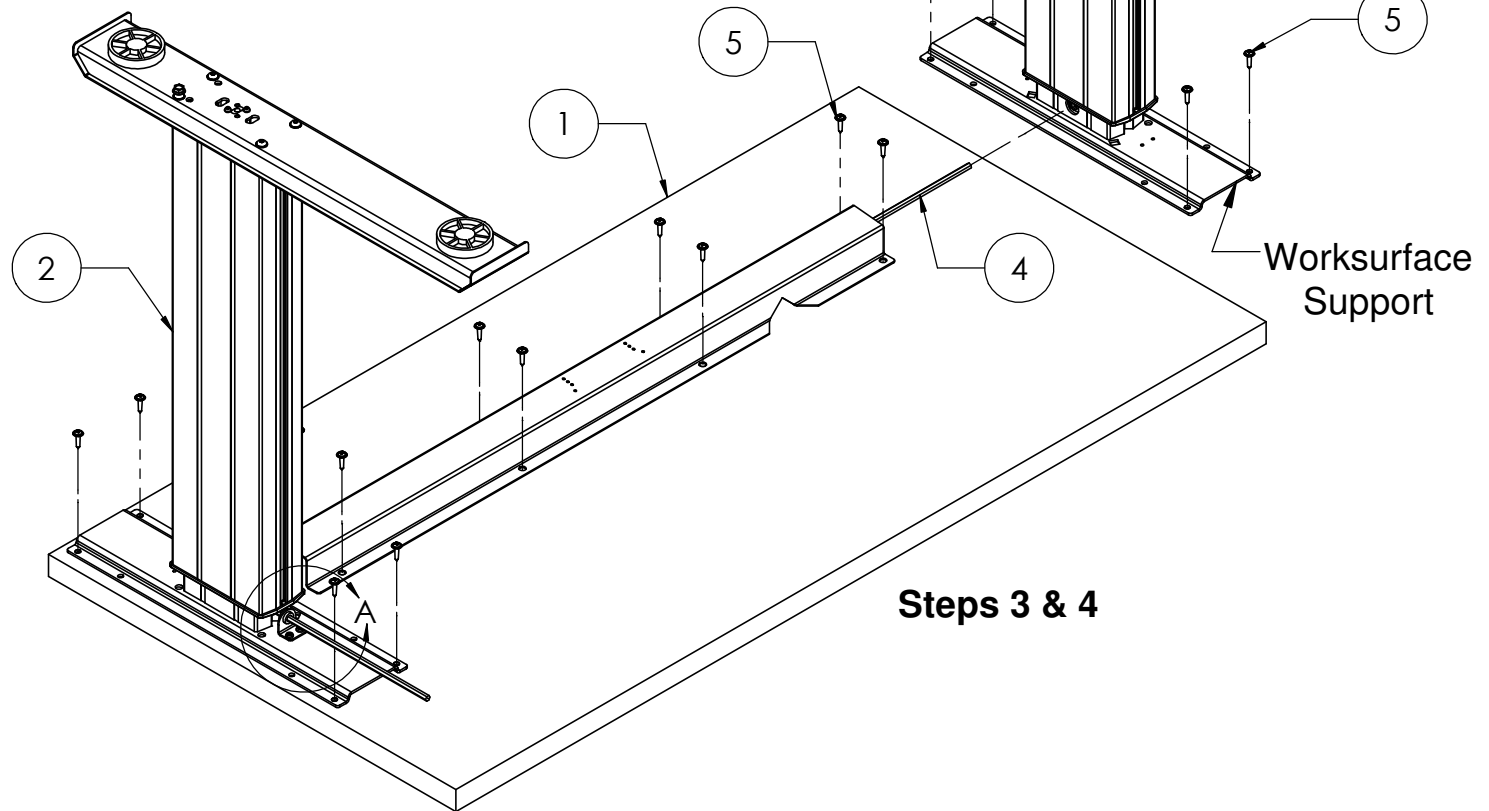

Steps 3 & 4

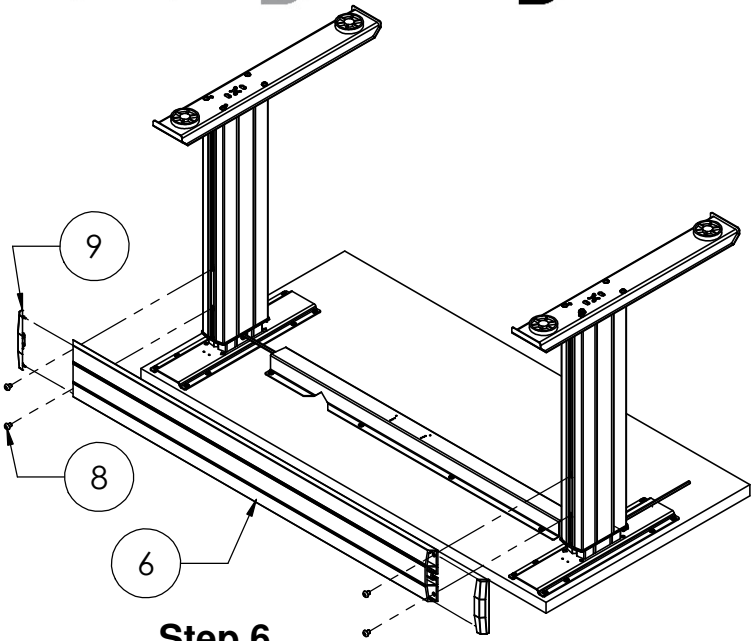

Step 6

Step 5: With the help of an assistant align the cross support with the stickers on both leg assemblies. See below. Insert (4) socket screws **8** through the holes in the ends of the cross support **6** and thread them into the weld nuts that are held in place by the stickers. Do not fully tighten. Check that the cross support is level and parallel to the worksurface. Fully tighten the socket screws.

Step 6; Insert (2) end caps **9** into the ends of the cross support **6**.

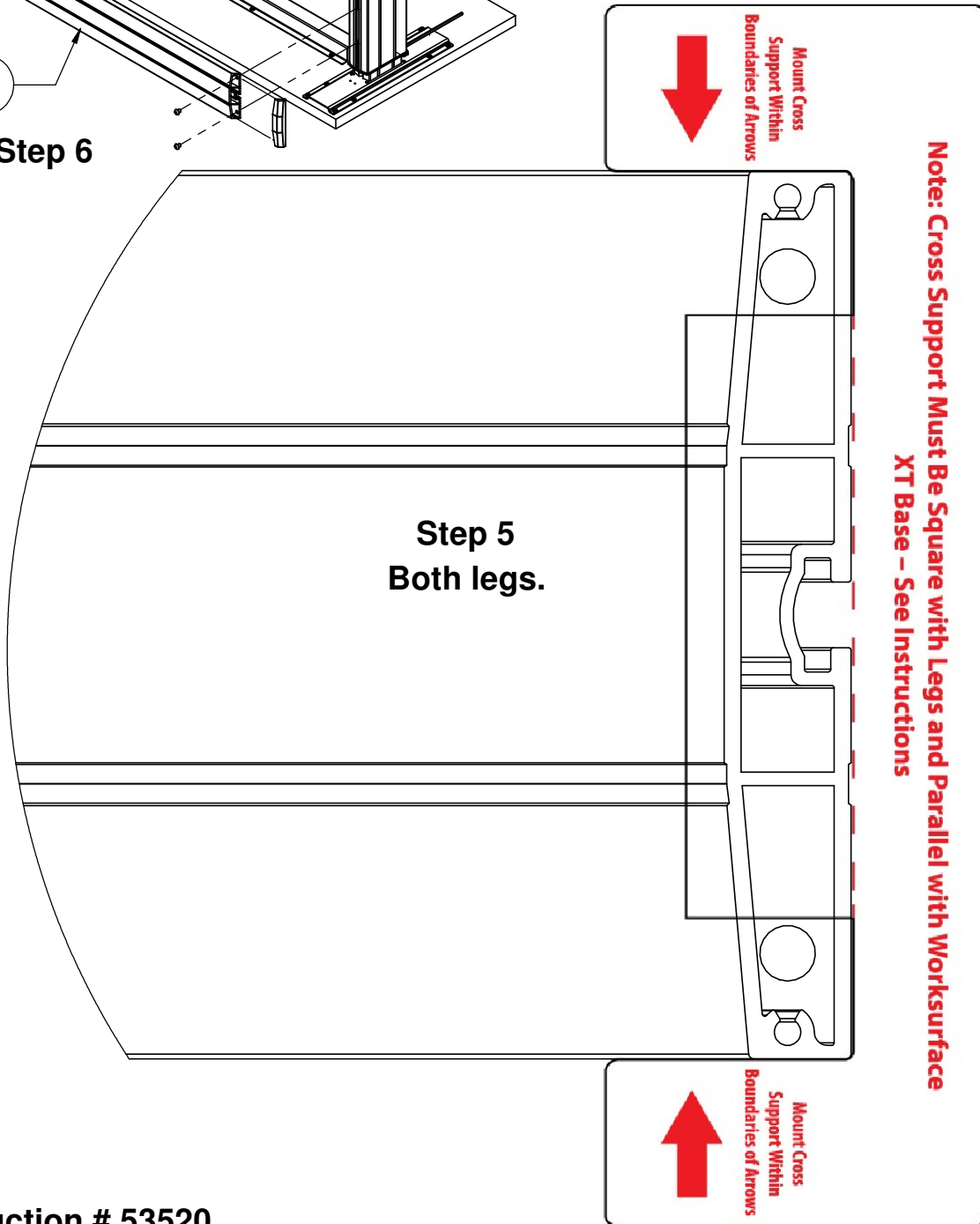

**Step 5
Both legs.**

Step 7: Slide the crank/bracket/clamp assembly **11** onto the hex rod protruding from the front of the right leg assembly **2**. Align the holes in the bracket with the pilot holes in the worksurface **1**. Attach it with (4) wood screws **5**.

Step 8: With the help of an assistant, set the workstation upright in its final location. Level the unit if required by turning the leveling glides clockwise (from the top) on the low corners of the workstation. If your workstation has casters, level it by turning the bolts at the top of the casters.

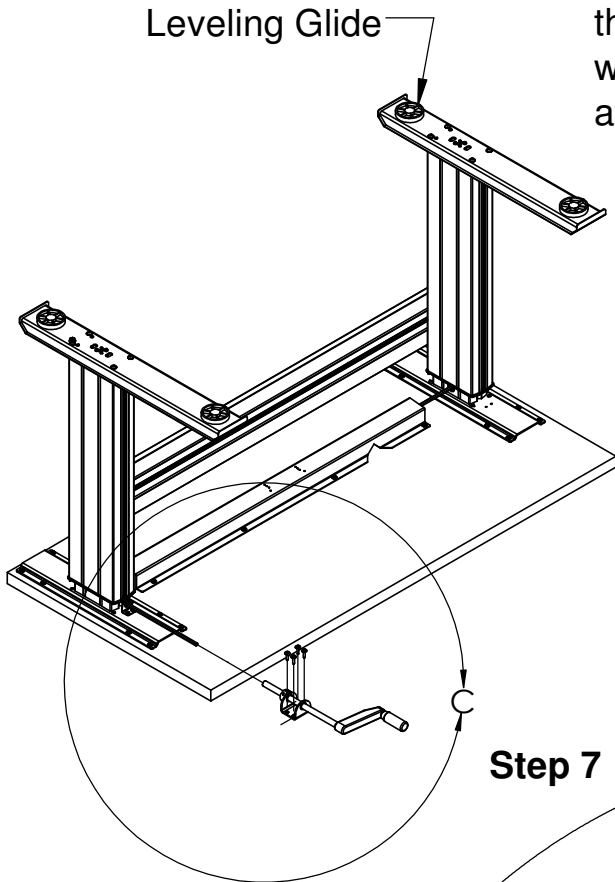

Note: The position of the crank handle can be adjusted in or out by loosening the screw in the clamp and sliding the crank handle to the desired position. Place the clamp against the back of the bracket and re-tighten the screw.

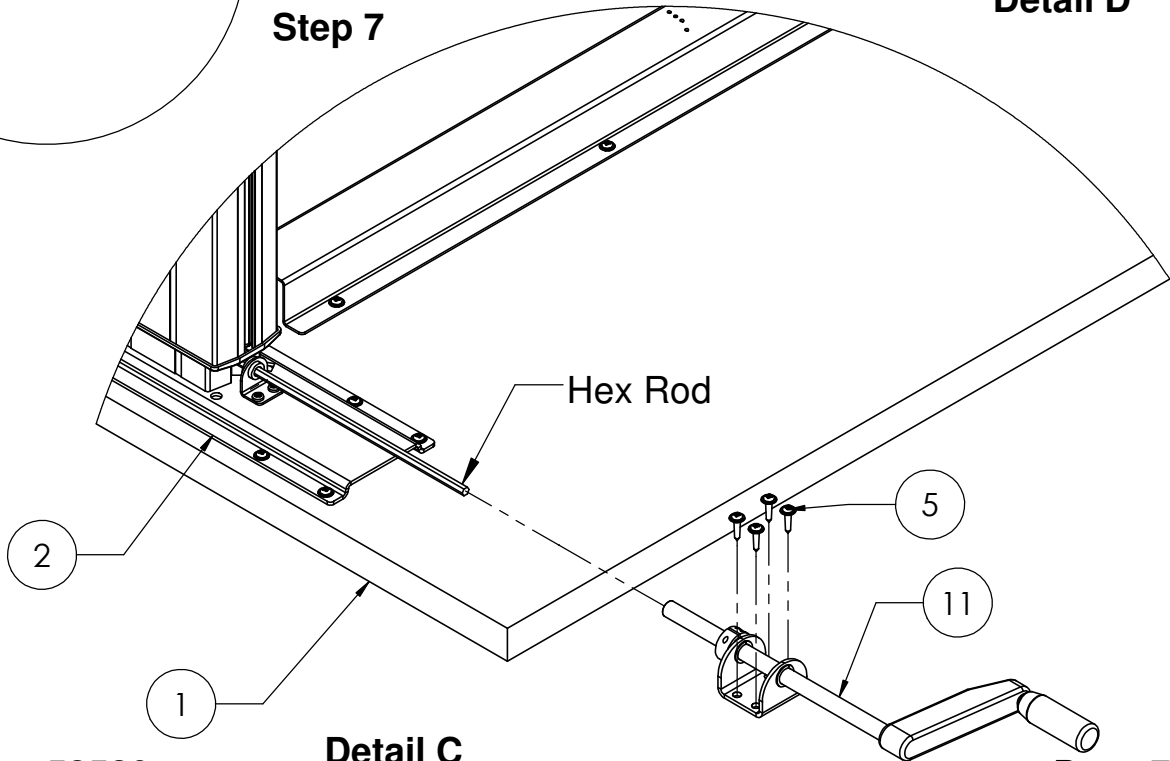
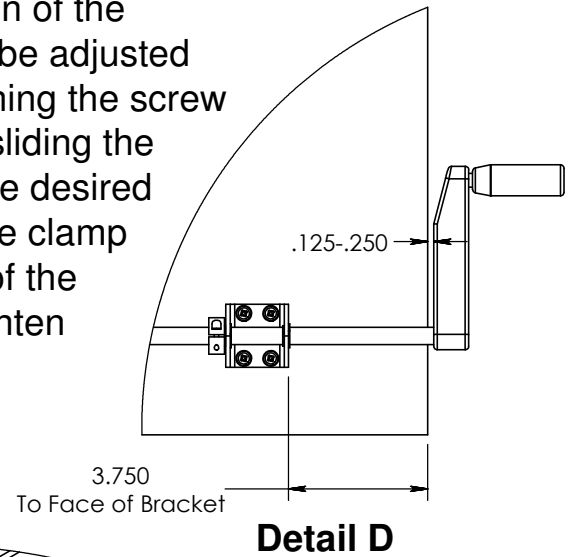



K&A Manufacturing

6703 Zinser Street Schofield, WI 54476
 Phone: 800.298.4351
 Fax: 866.882.9475
 www.raproducts.com

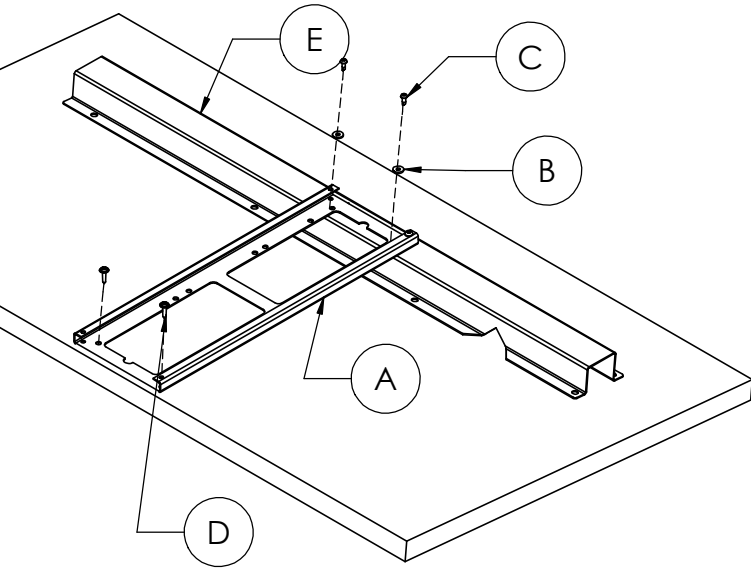

Instructions To Install a Track on a Series 4 Workstation:

Step 1: Place the front of the track **A** against the bottom of the worksurface and the back of the track against the u-channel.

Step 2: Align the holes in the track **A** with one set of pilot holes in the u-channel **E** keeping the front of the track 1/8"-5/8" from the front of the worksurface. Place (2) washers **B** on (2) self drilling screws **C**. Drive them through the track and into the u-channel.

Step 3: Attach the front of the track **A** to the worksurface using (2) wood screws **D**. Do not overtighten the screws. Use a low torque setting on the power driver.

Step 4: Complete the installation using the instructions that came with the product you are installing.

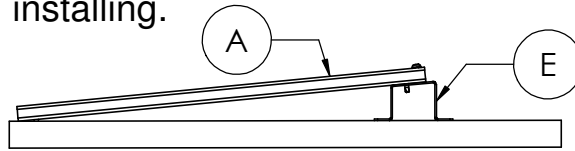

Side View
 (Track will be at an angle when installation is finished.)

ITEM #	PART #	DESCRIPTION	QTY.
A	Varies	Track Assembly	1
B	52336	3/16" Aluminum Rivet Washer .198 x .510 x .067	2
C	52678	8-18X1/2 Phillips Pan Self Drill Screw	2
D	51708	M5 x 18mm (7/8") Sq/Ph/Wshr Head Wood Screw	2
E	Varies	LT U-channel	1

Troubleshooting: If the workstation leg assemblies are at uneven heights, it is usually caused by an improperly installed hex rod. Disassemble one of the legs from the worksurface and make sure both ends of the hex rod are properly engaged in the hex drives near the tops of the leg assemblies.

If you continue having problems with the table operation, contact RightAngle™ service at 800-298-4651 or orders@raproducts.com.