

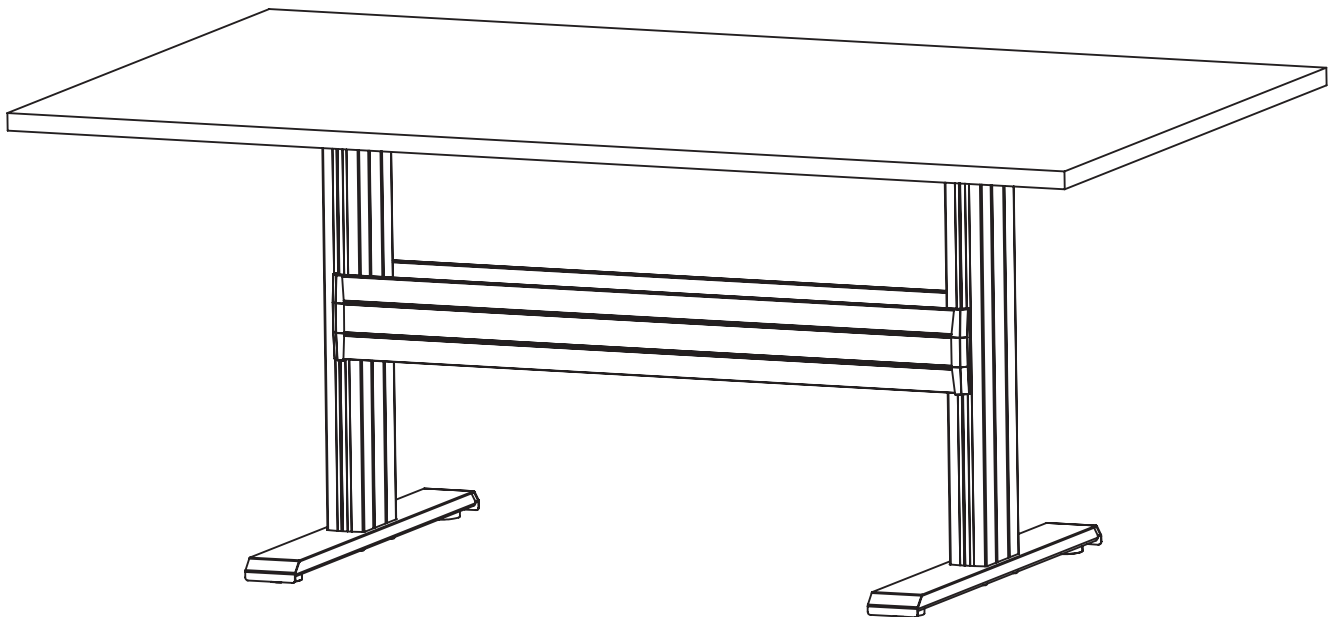



NewHeights™ Fixed Conference Desk Assembly Instructions
Warranty: raproducts.com/warranty

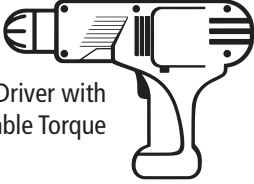

Failure to comply with or observe all assembly, safety, and operation instructions and warnings regarding the use of this product may result in serious property damage or bodily injury.

Tools **Required** for Assembly:



Power Driver with Adjustable Torque



Tape Measure



#2 Square Head Driver Bit

Hardware **Included** for Assembly:

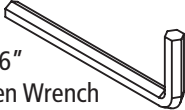

3/16" Allen Wrench

May have extra hardware



1
3/4" Wood Screw
51708 *xVaries*



2
Socket Screw
x8

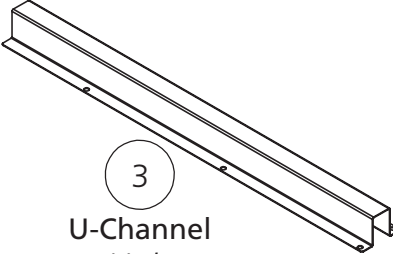

3
U-Channel
xVaries

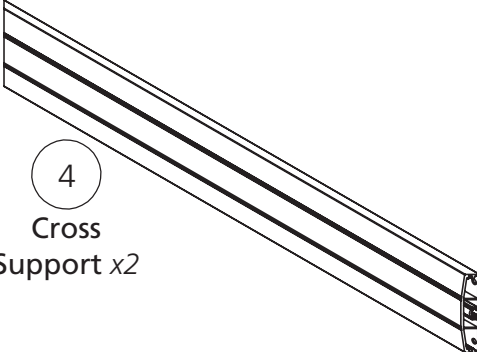

4
Cross Support *x2*

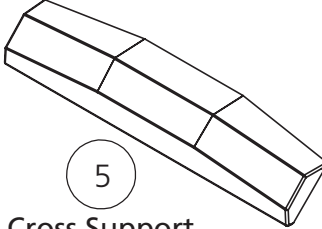

5
Cross Support Cover *x4*

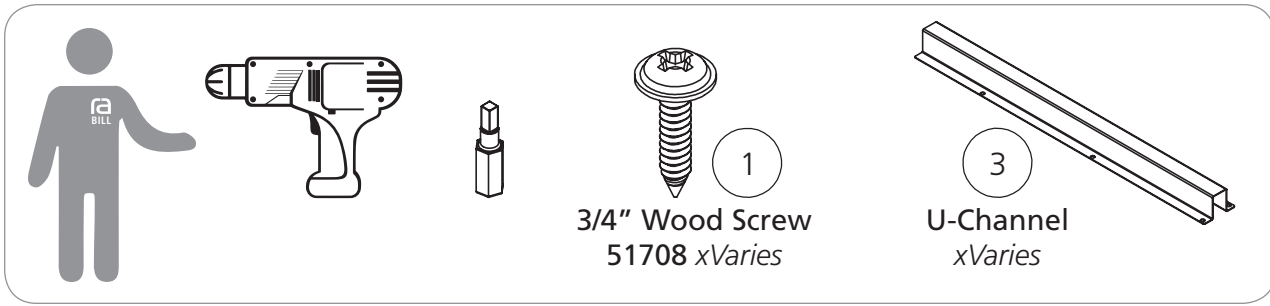

The following instruction illustrates a RightAngle manufactured base and work-surface. If your worksurface is from another manufacturer, you are responsible for the base and worksurface hole alignment.

1

- Lay worksurface on a protected surface.
- Align **#3** U-channels with pre-drilled pilot holes.
- Screw **#3** U-channels in place with **#1** wood screws.

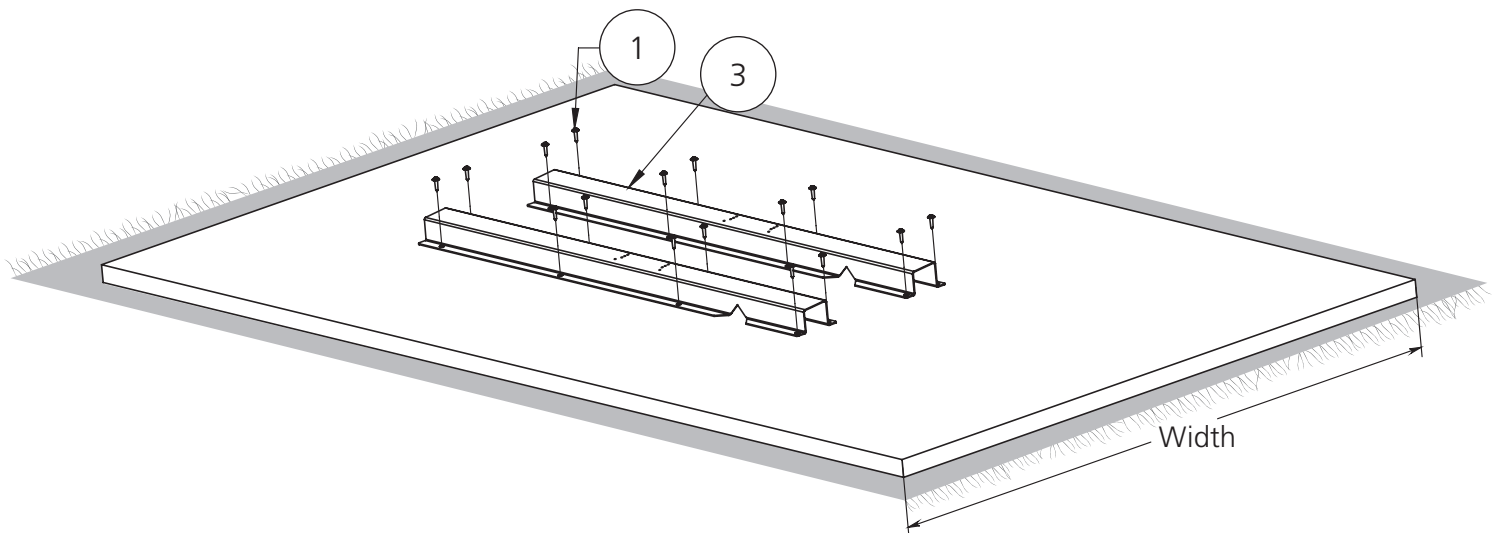
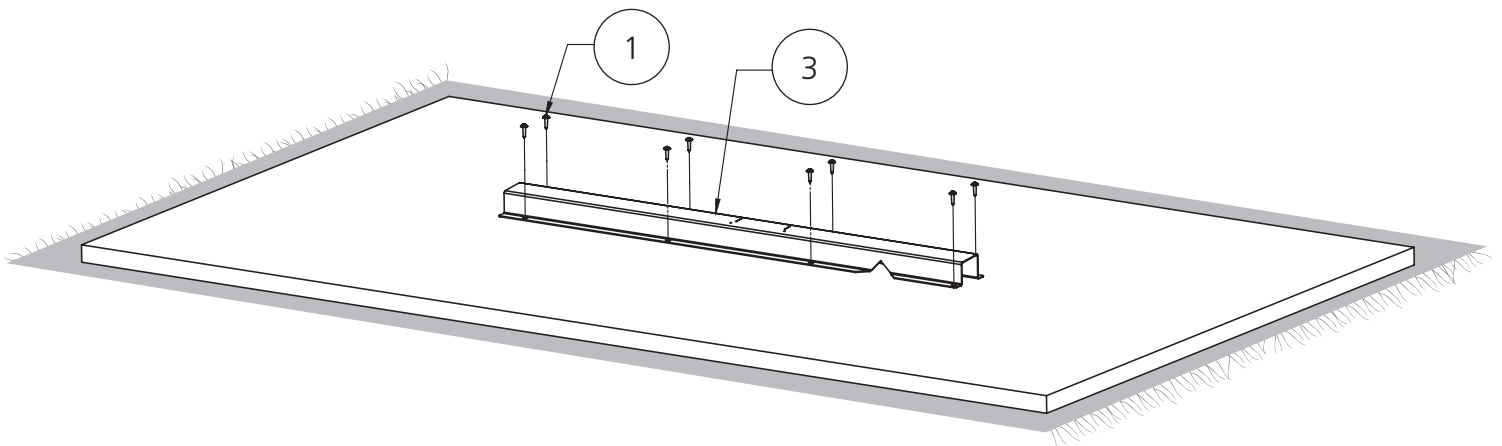

Note: When worksurface width is over 42" you will have multiple U-channels.

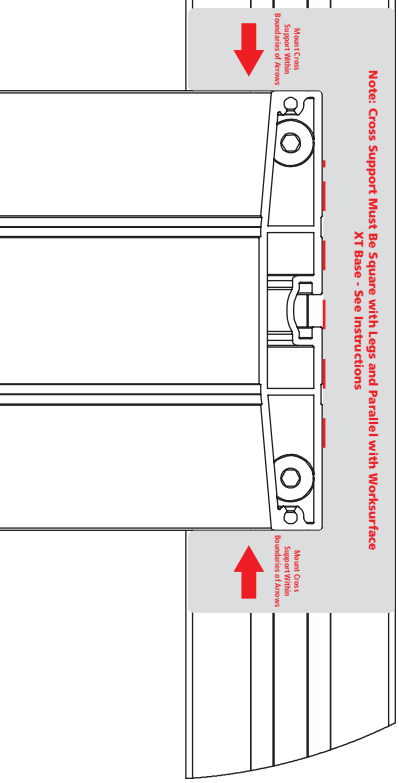
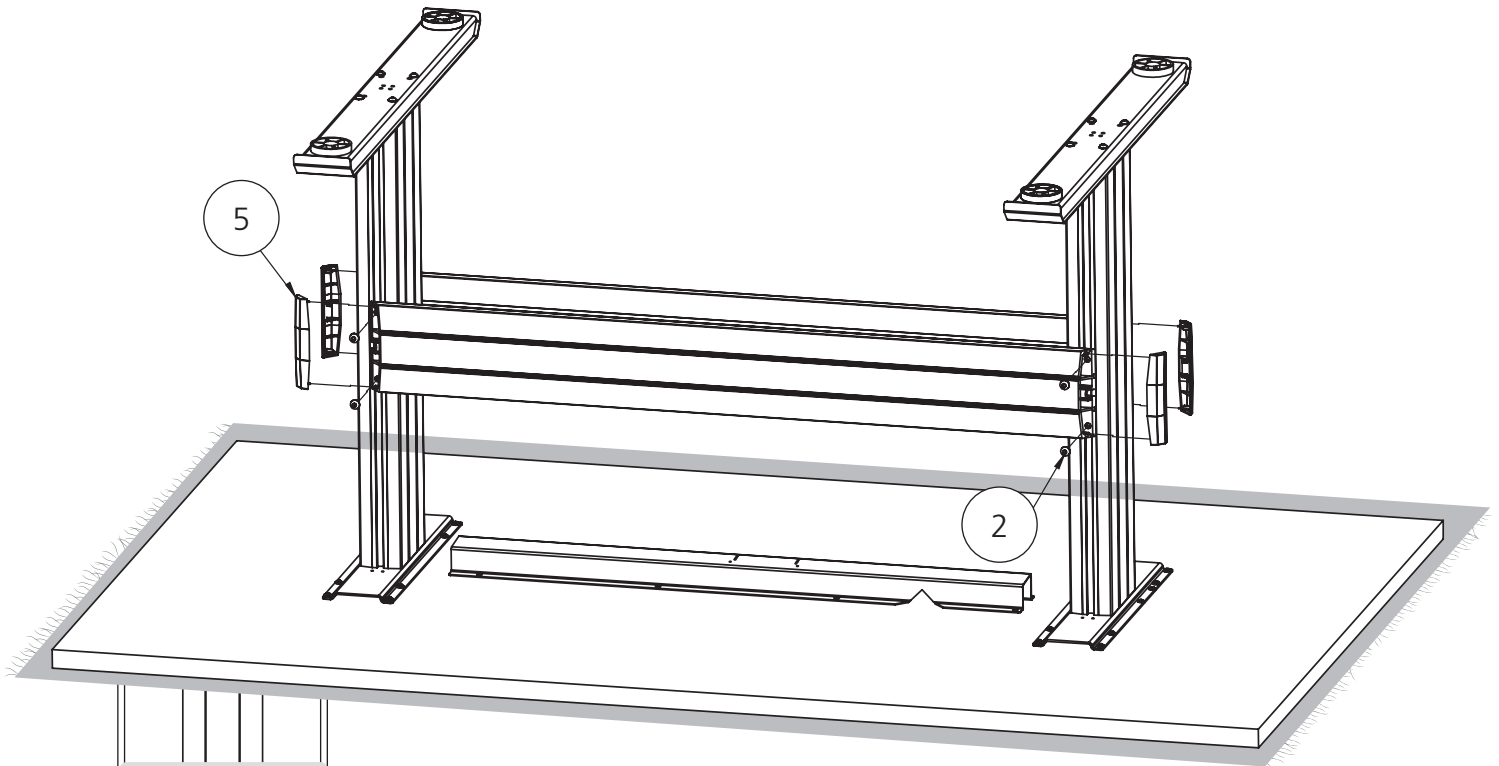
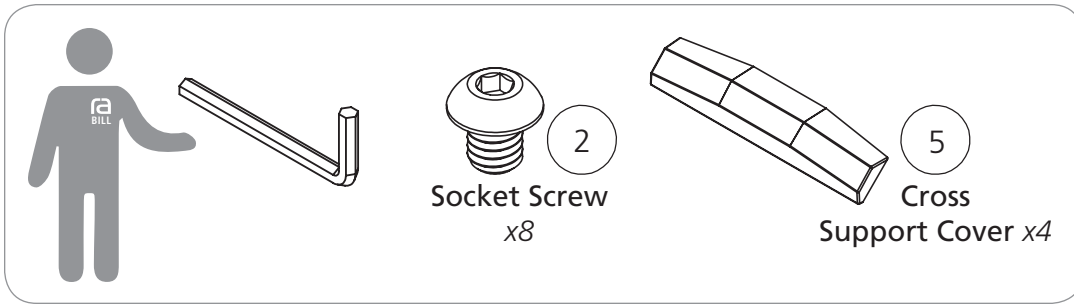

Align cross support over the leg stickers.

2

- Install **#2** socket screws through the cross support holes and into the weld nuts held in place by the leg stickers. Do this to both cross supports using four (4) screws per support.
- Install **#5** cross support covers by snapping them into the cross support ends.

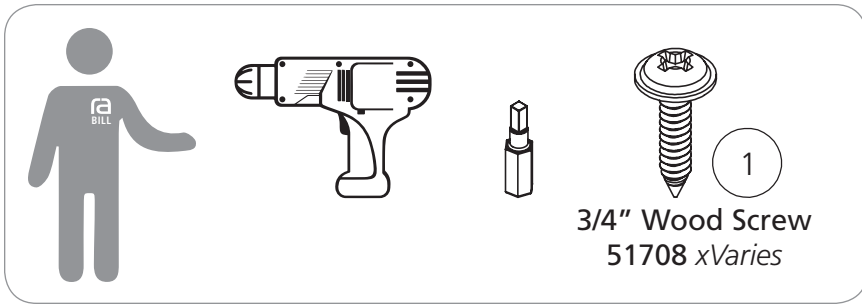

3

- Align assembled base with pre-drilled pilot holes.
- Screw in base with **#1** wood screws.

Do not overtighten.

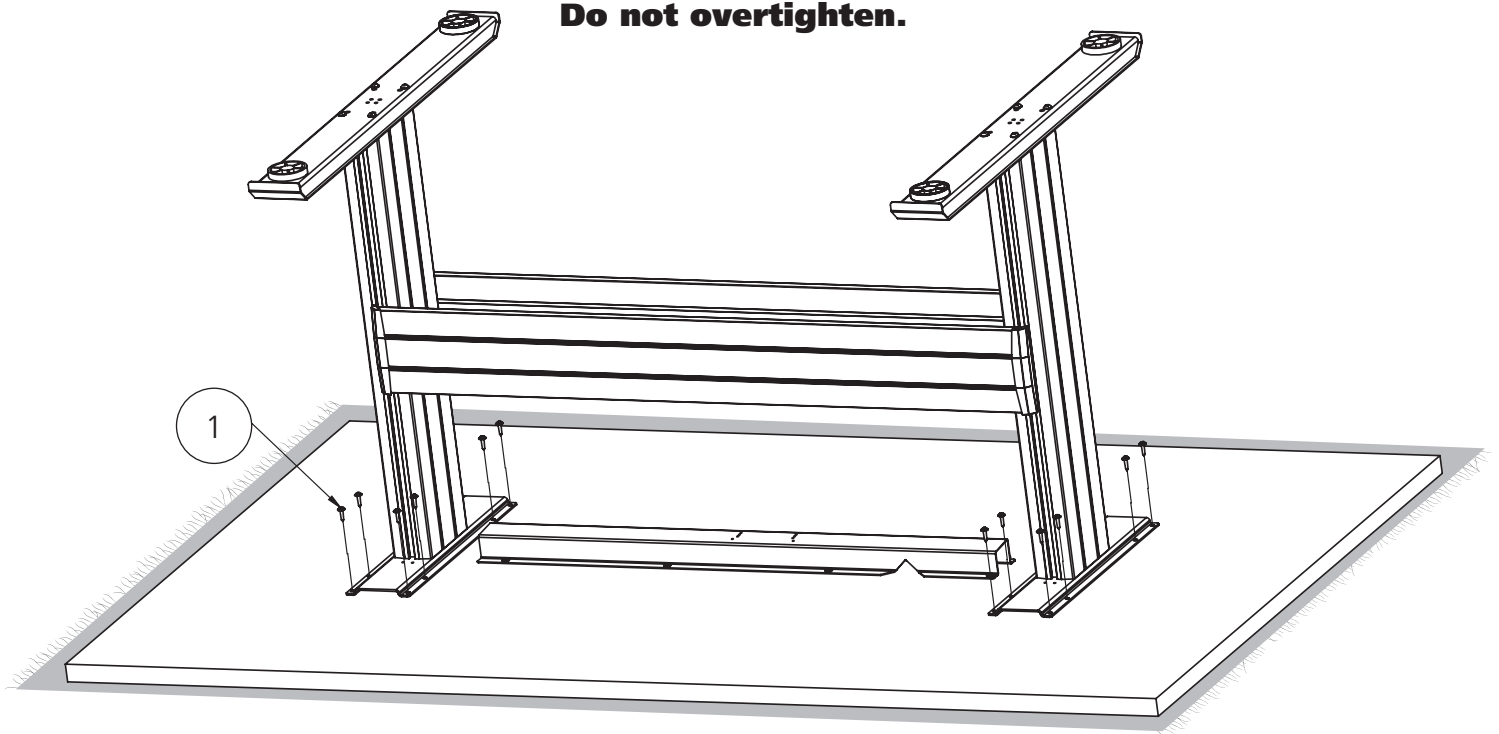

Note: This workstation is used with a variety of bases. Your worksurface and base may have extra holes.