

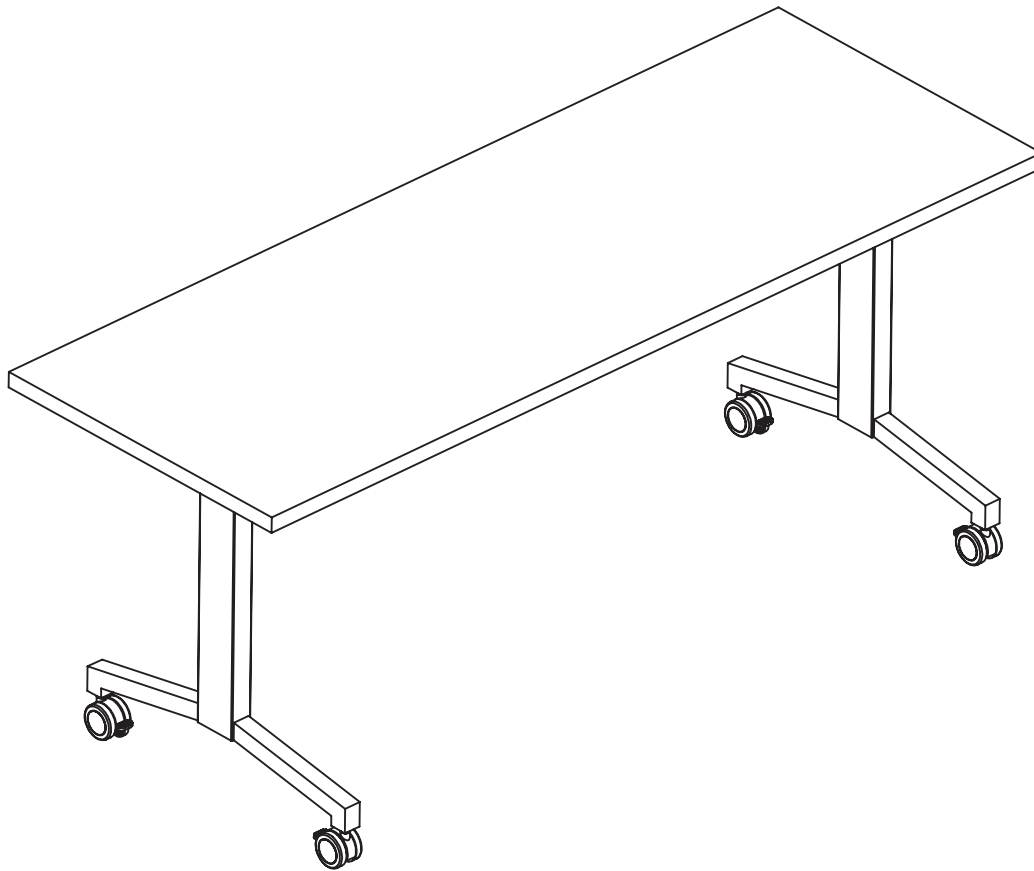

R-Style Flip Table Assembly Instructions

Warranty: raproducts.com/warranty



Failure to comply with or observe all assembly, safety, and operation instructions and warnings regarding the use of this product may result in serious property damage or bodily injury.

Make sure no obstacles are in the desk's path and all cords are of appropriate length for the desk. Always maintain a 1" clearance around the table to prevent pinching.

Never assemble (or disassemble) the table or components with the table plugged into a power outlet. This product is for use on a nominal 120-volt circuit and has a grounding plug. Make sure that the product is connected to an outlet having the same configuration as the plug. No adapter should be used with this product.

Tools Required for Assembly

R-Style Flip Table #54061

- A. Power Driver with Adjustable Torque
- B. Tape Measure
- C. #2 Phillips Head Driver Bit
- D. #2 Square Head Drive Bit (**Recommended**)

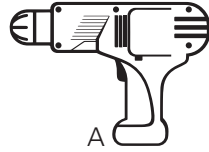

A



B



C



D

Hardware and Tools Included for Assembly (may have extra)

- E. 8mm x .625 Machine Screw **x8**



E

- F. 8mm x .75 Thread Screw **x8**



F

- G. #10 x 1.0 Wood Screw **x1**



G

- H. #10 x .75 Wood Screw **x10**



H

- I. 10 x .75 Spacer Wood Screw **x2**



I

- J. Caster Wrench **x1**

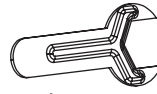

J

- K. 5mm Allen Wrench **x1**



K

- L. 2mm Allen Wrench **x1**



L

- M. Caster Leveling Nut **x4**



M

- N. Front Bumper **x2**



N

- O. Clear Bumper **x2**



O

- P. Set Screw **x2**



P

- Q. Worksurface Bumper **x1**

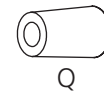

Q

- R. Spacer **x2**

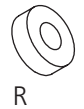

R

Flip Table Parts

- S. Casters **x4**



S

- T. Leg Assemblies **x2**

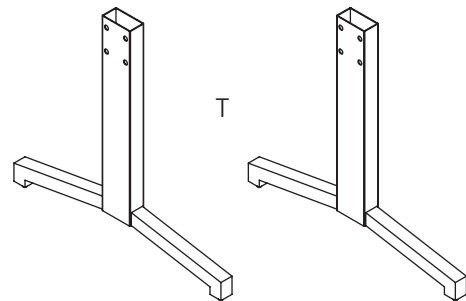

T

- U. Main Beam **x1**

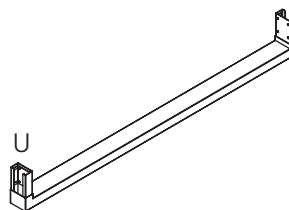

U

- V. Hinge Mechanisms **x2**

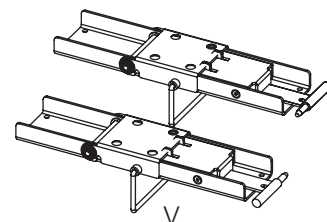

V

- W. Pull Bar **x1**



W

Step 1

- Screw all four leveling nuts onto the caster stems using the caster wrench.

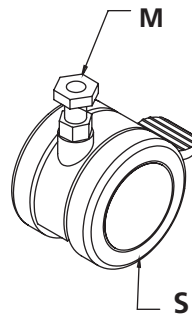
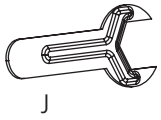

Step 2

- Screw the casters onto both leg assemblies.

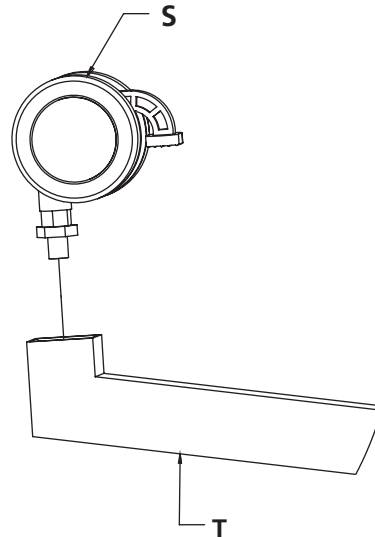
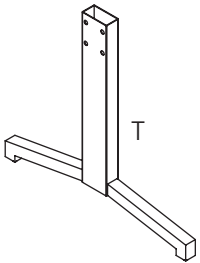

Step 3

- Lay the beam on a protective surface with the insert channels facing up.
- Place one of the leg assemblies over the main beams sliding the insert into the hollow leg assembly. The leg assemblies are interchangeable.
- Insert the screws into the leg and fully tighten. Do this to both legs.

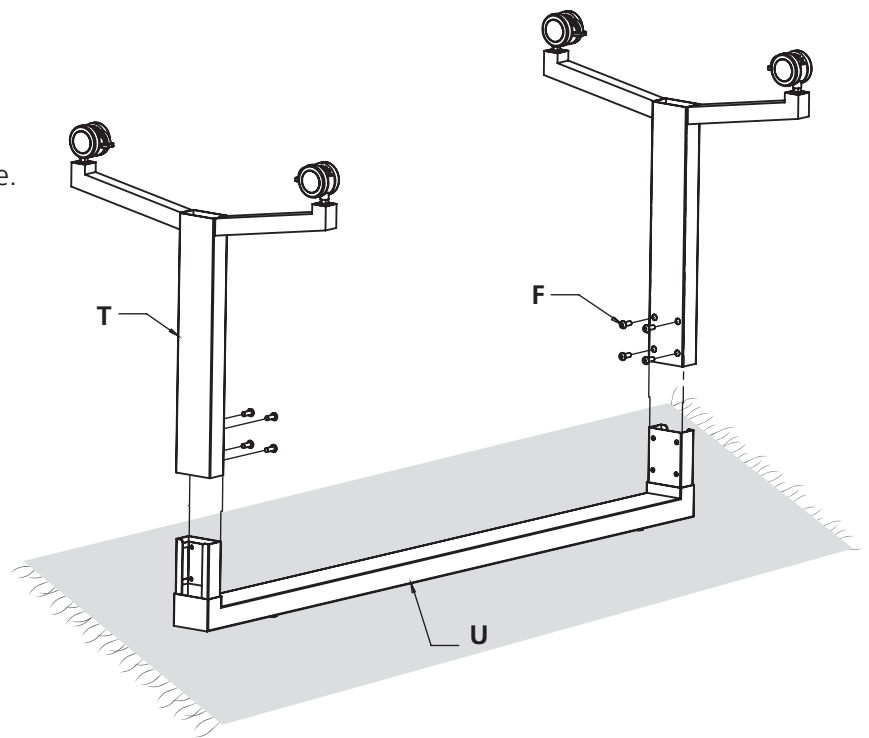
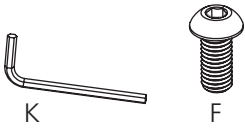

Step 4

- Set the main beam and leg assembly upright.
- Peel the backing off two front bumpers and attach them to the main beam. Locate them about 6-1/4" from the ends of the beam and on center.

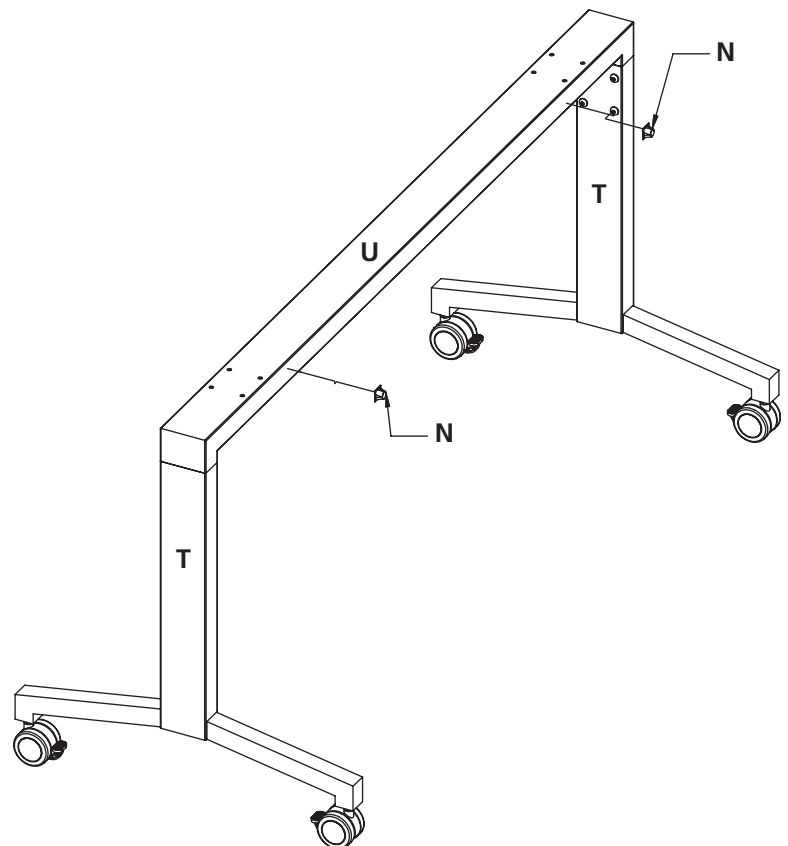

Step 5

- Set the hinge mechanisms on the main beam.
- Open up both mechanism assemblies by pulling out the pins.
- Place the retainer into the slots on the body of the mechanisms. This is to lock them from closing.

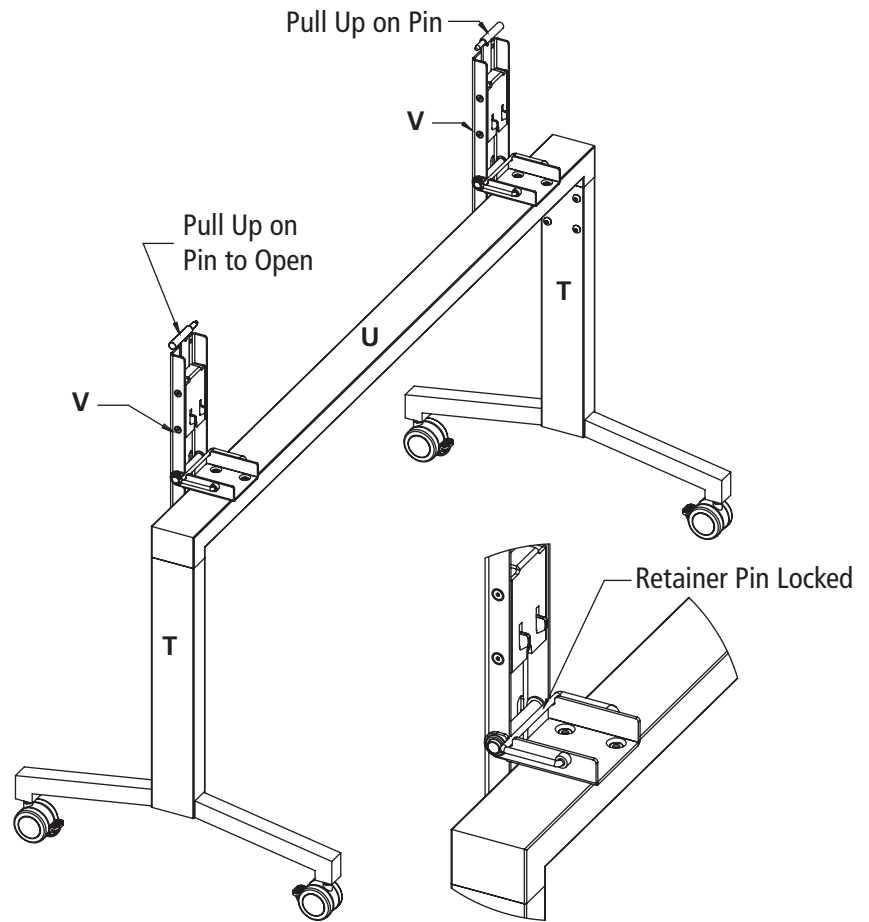

Step 6

- Peel the backing off of two clear bumpers and attach them to the mechanism assembly. Center them in front of the screw holes as shown.

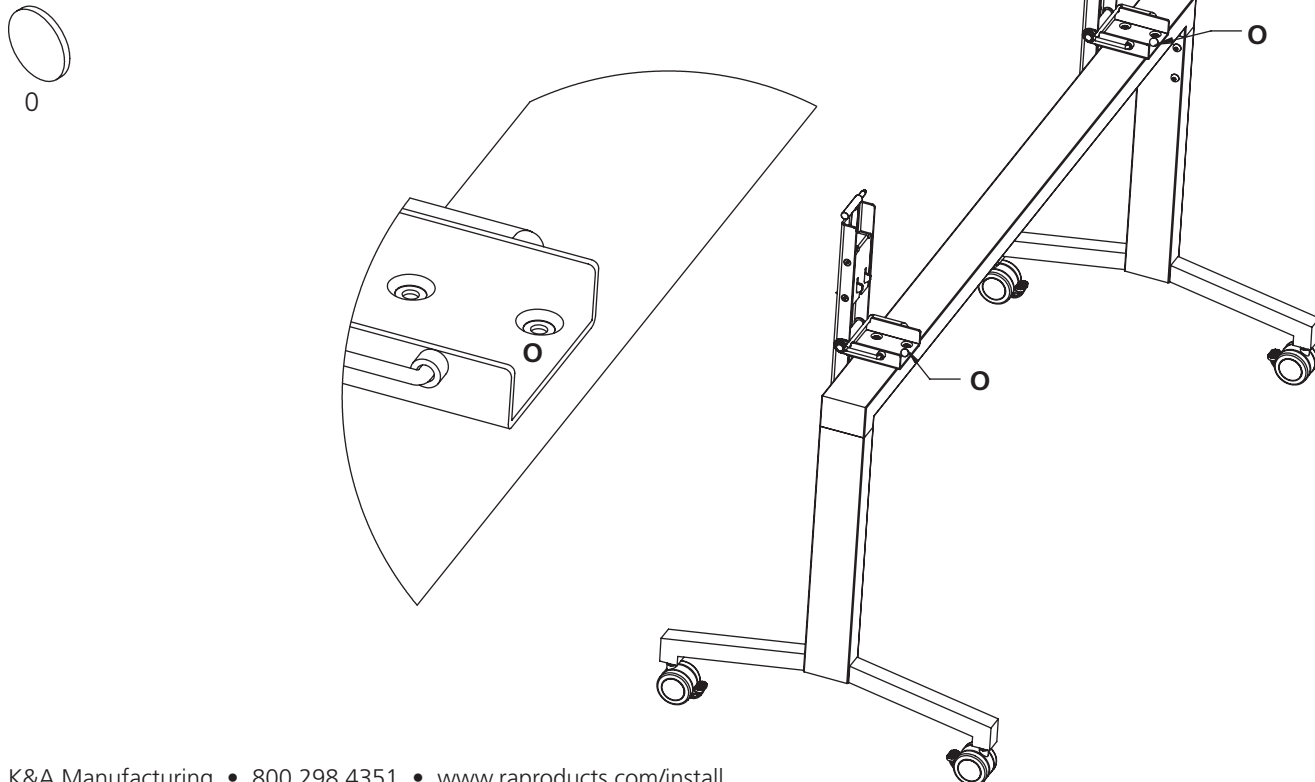

Step 7

- Place the pull bar on the mechanisms ends rotating them so the set screw holes face the bottom side of the worksurface.
- Thread the set screws on with the allen wrench.

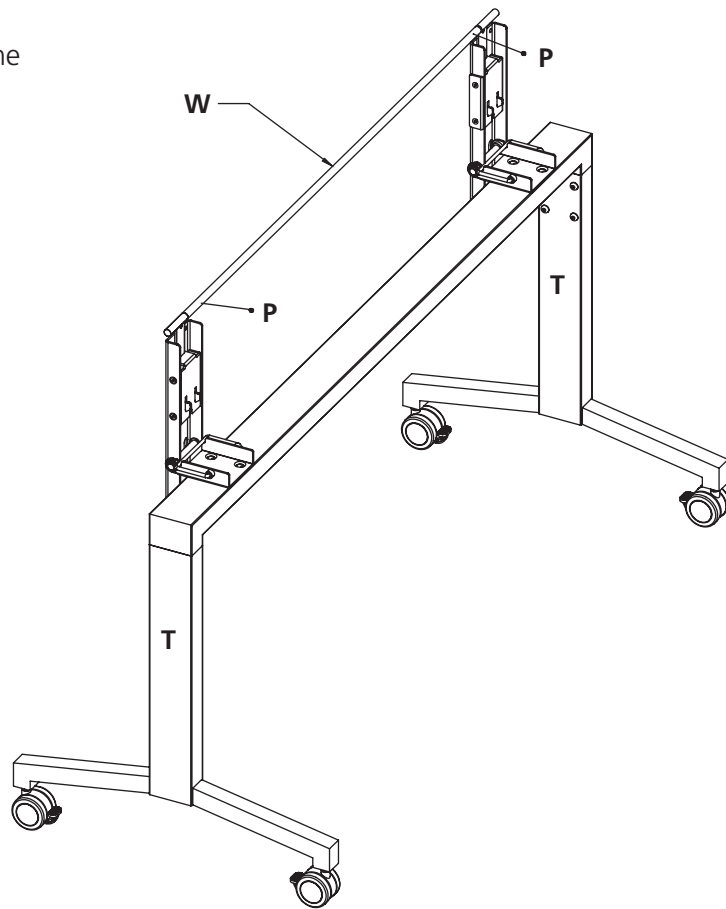

Step 8

- Place the left and right mechanisms on the main beam and open them up.
- Attach with four screws and fully tighten.

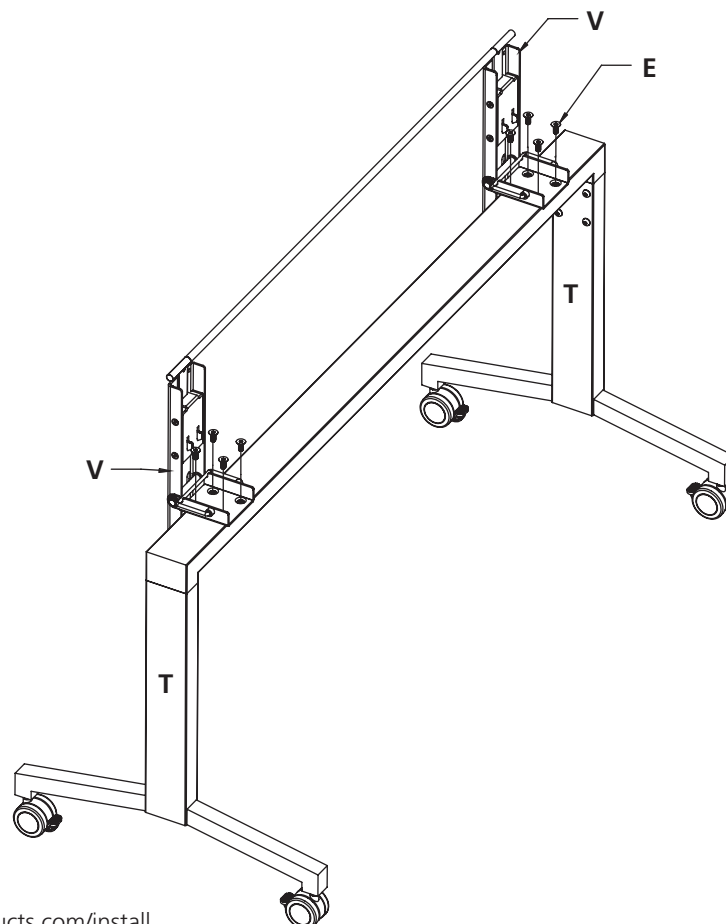
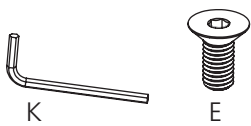

Step 9

R-Style Flip Table #54061

- Place the worksurface on a protected surface with the pilot holes facing up.
- Unlock the retainers on the base and close the mechanism assemblies by pulling out on the connector tube, and rotating the assemblies until they lock into place.
- Set the base on top of the worksurface.

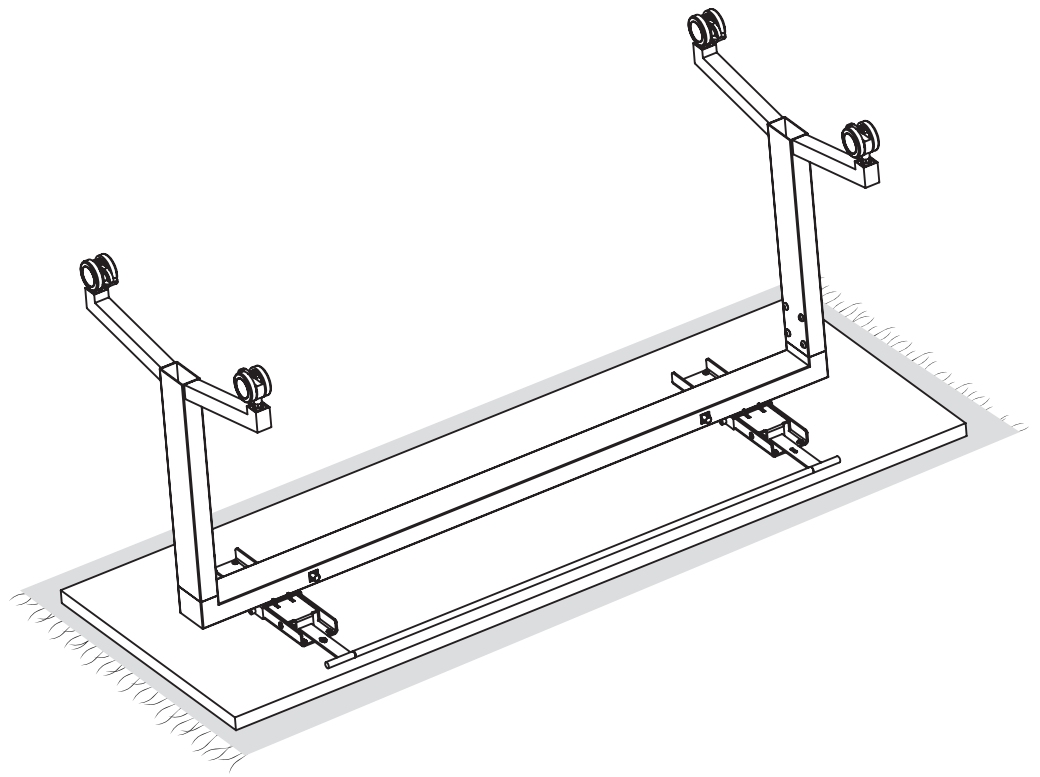

Step 10

- Place the assembled base onto the worksurface.
- Align the holes in the mechanisms with the pilot holes on the worksurface.
- Attach with four wood screws into the outside corners of each. Do not over-tighten.

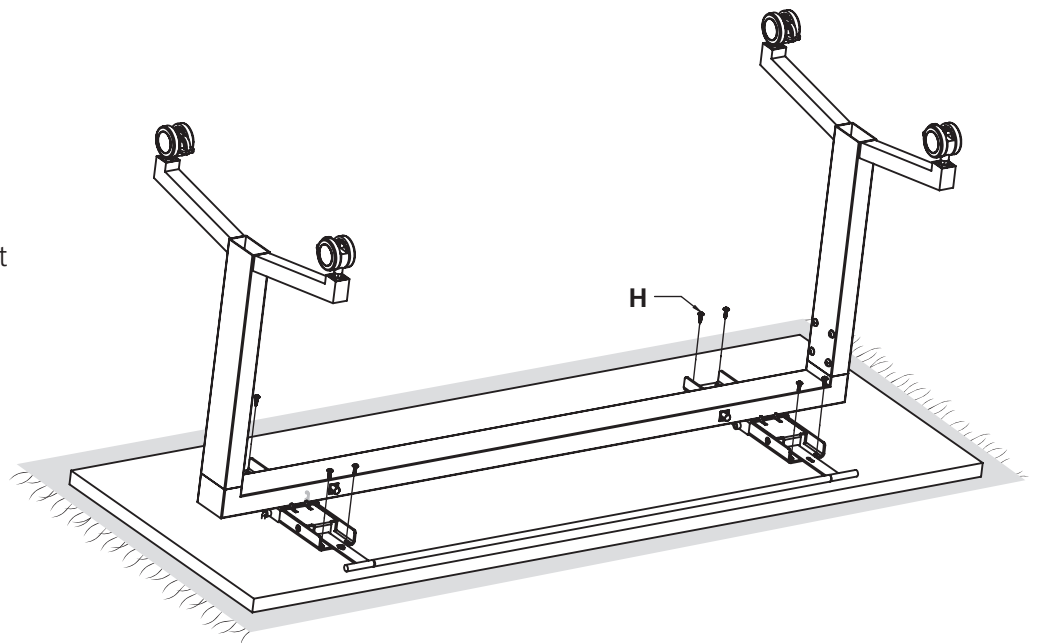
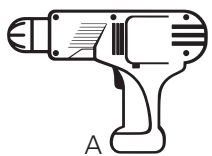

Step 11

- Place the assembled base on its caster wheels.
- Pull out on the pull bar and flip the table in the vertical position.
- Place the retainers into the slots to lock it into place.
- Drive one wood screw into the center of each mechanism, fully tighten.

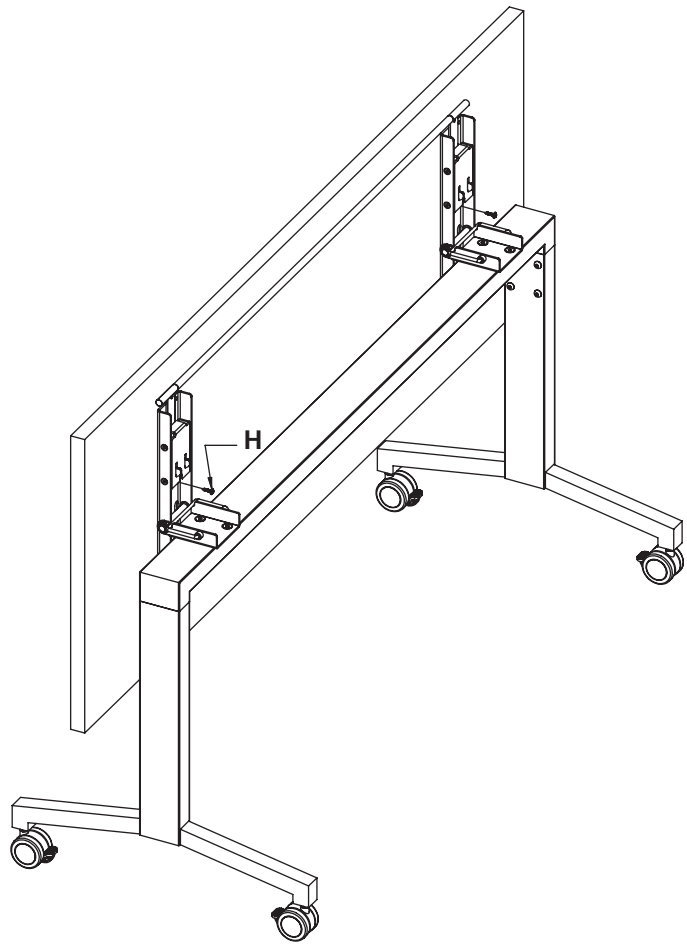
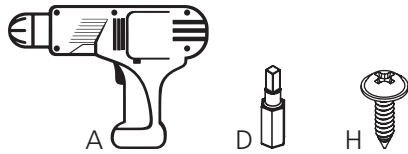

Step 12

This step applies to 60" and 72" flip tables only.

- Place the unit on its casters and open up the mechanisms by pulling out on the pull bar.
- Measure the center of the worksurface (left to right) and align with the center of the main beam.
- Attach one bumper with a wood screw, no pilot hole is provided.

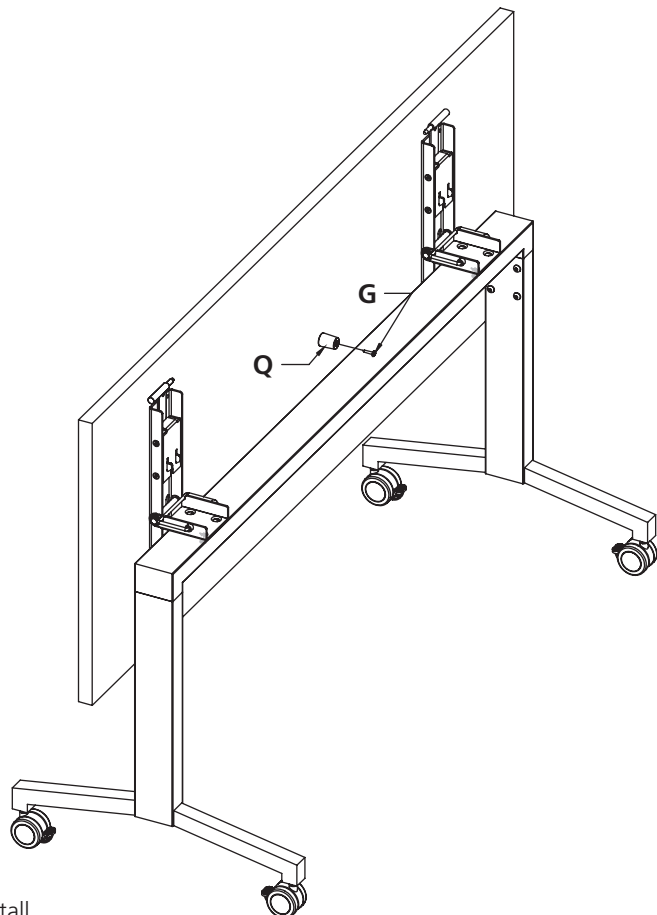
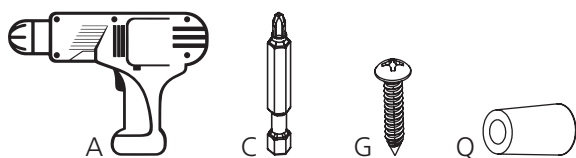

Step 13

- Place a spacer between the latch on each mechanism and the underside of the worksurface. Place the spacer tight to the forward end of the slot.
- Attach with wood screws. Tighten so the latch can still slide in and out.

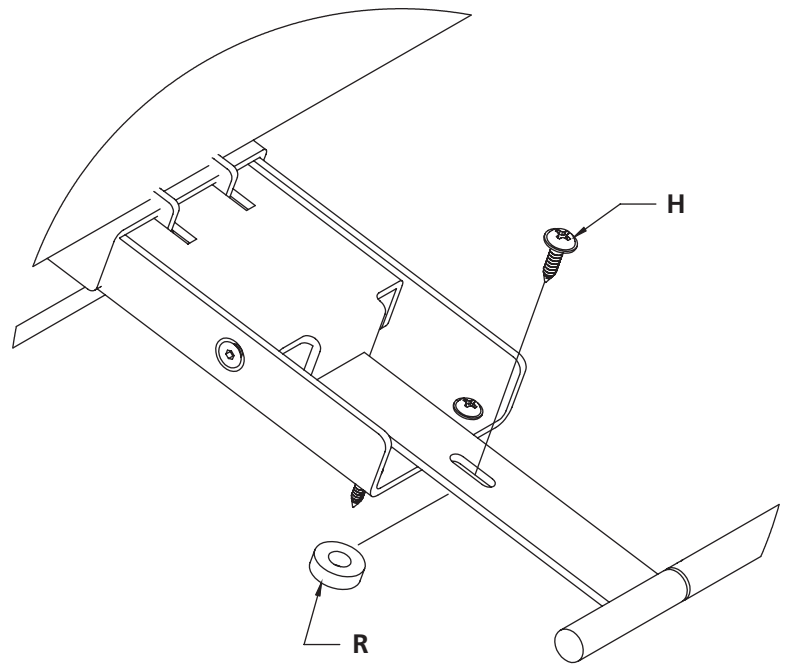
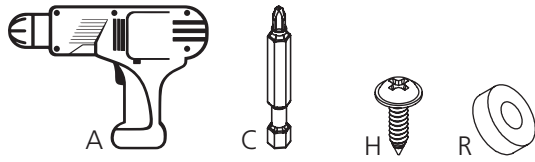

Operation

- To flip the worksurface to a vertical position, pull out on the connector bar, and rotate the worksurface upward.
- Place the retainers into the slots on the body of the mechanisms to secure it. **Securing the worksurface with the retainers in the vertical position is critical for safety reasons.**
- To place the worksurface in the horizontal position, pull the retainers out of the slots and rotate the worksurface downward until the mechanisms lock into place.