

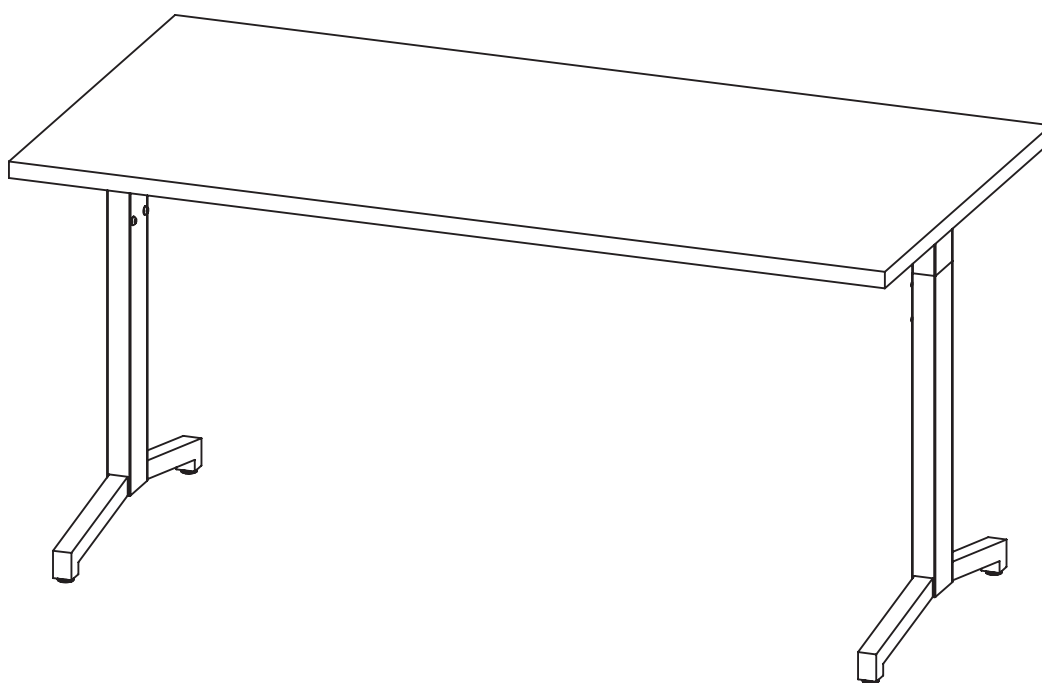

R-Style T-Base Table Assembly Instructions

Warranty: raproducts.com/warranty



Tools Required for Assembly

- A. Power Driver with Adjustable Torque
- B. Tape Measure
- C. #2 Square Head Drive Bit (**Recommended**)
- D. #2 Phillips Head Driver Bit (**Recommended**)

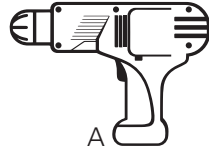

A



B



C



D

Hardware, Tools and Parts Included for Assembly *(may have extra)*

- E. 8mm x .75 Thread Screw **x16**
- F. 5/8" Wood Screw **x12**
- G. 5mm Allen Wrench **x1**
- H. Beam **x1**
- I. Center Hinge **x1**
- J. Left Hinge **x1**
- K. Right Hinge **x1**
- L. Left Leg **x1**
- M. Right Leg **x1**



E



F

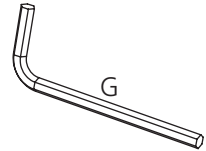

G

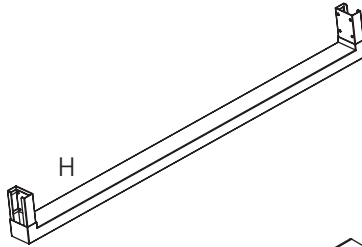

H

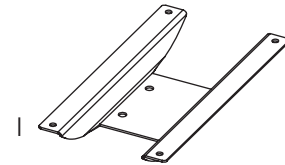

I

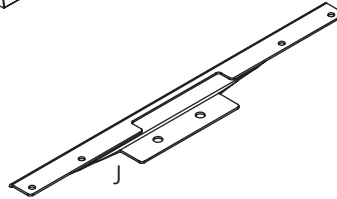

J

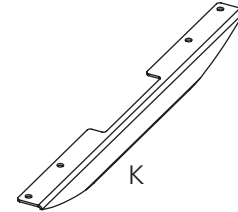

K

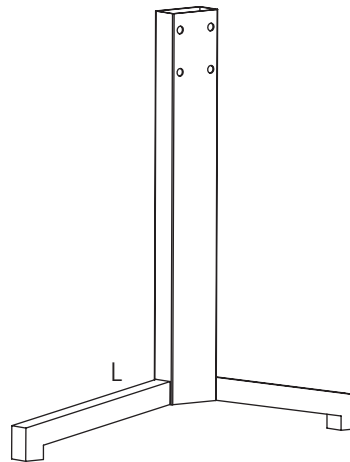

L

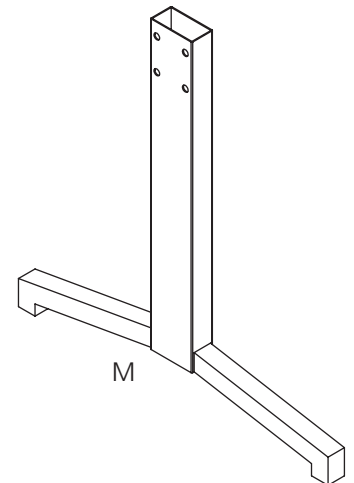

M

Step 1

- Lay the beam on a protective surface with the insert channels facing up.
- Place one of the leg assemblies over the main beam sliding the insert into the hollow leg assembly. The leg assemblies are interchangeable.
- Insert the screws into the leg and fully tighten. Do this to both legs.

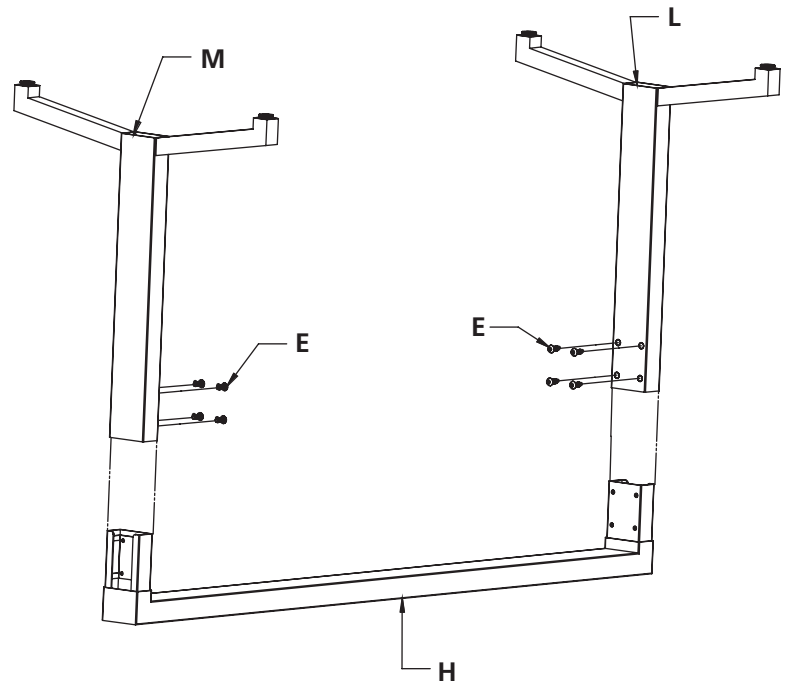
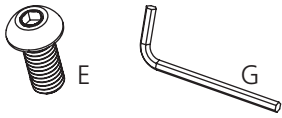

Step 2

- Set the left and right hinges on the main beam.
- Attach four screws through the hinges and into the main beam.

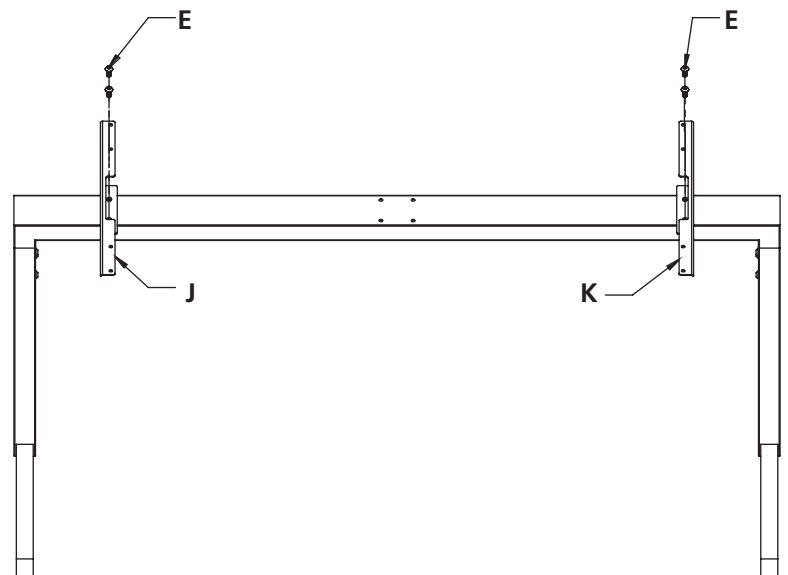
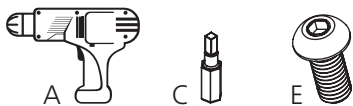

Step 3

- Set the hinge mechanism onto the main beam and attach with four machine screws.

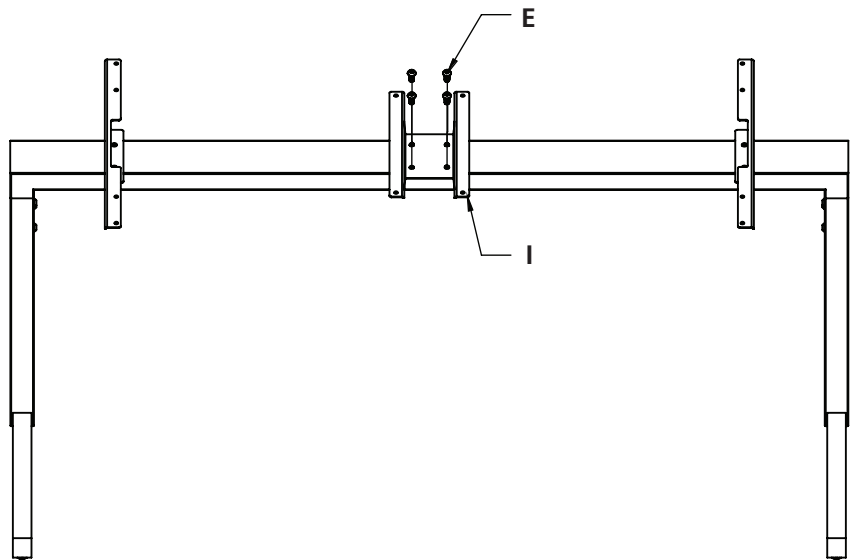
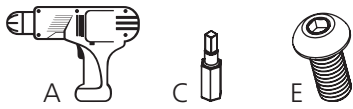

Step 4

- Lay the worksurface onto a protected surface with the pilot holes facing up.
- Attach the worksurface to the mechanism and both hinges with wood screws.

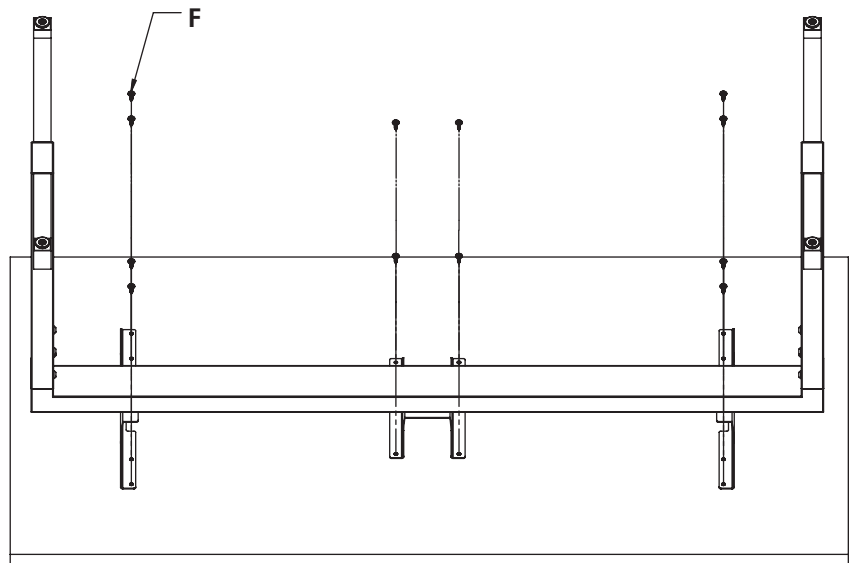
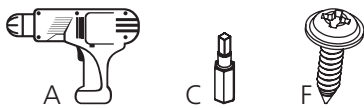

Step 5



Get help lifting heavy items.

