

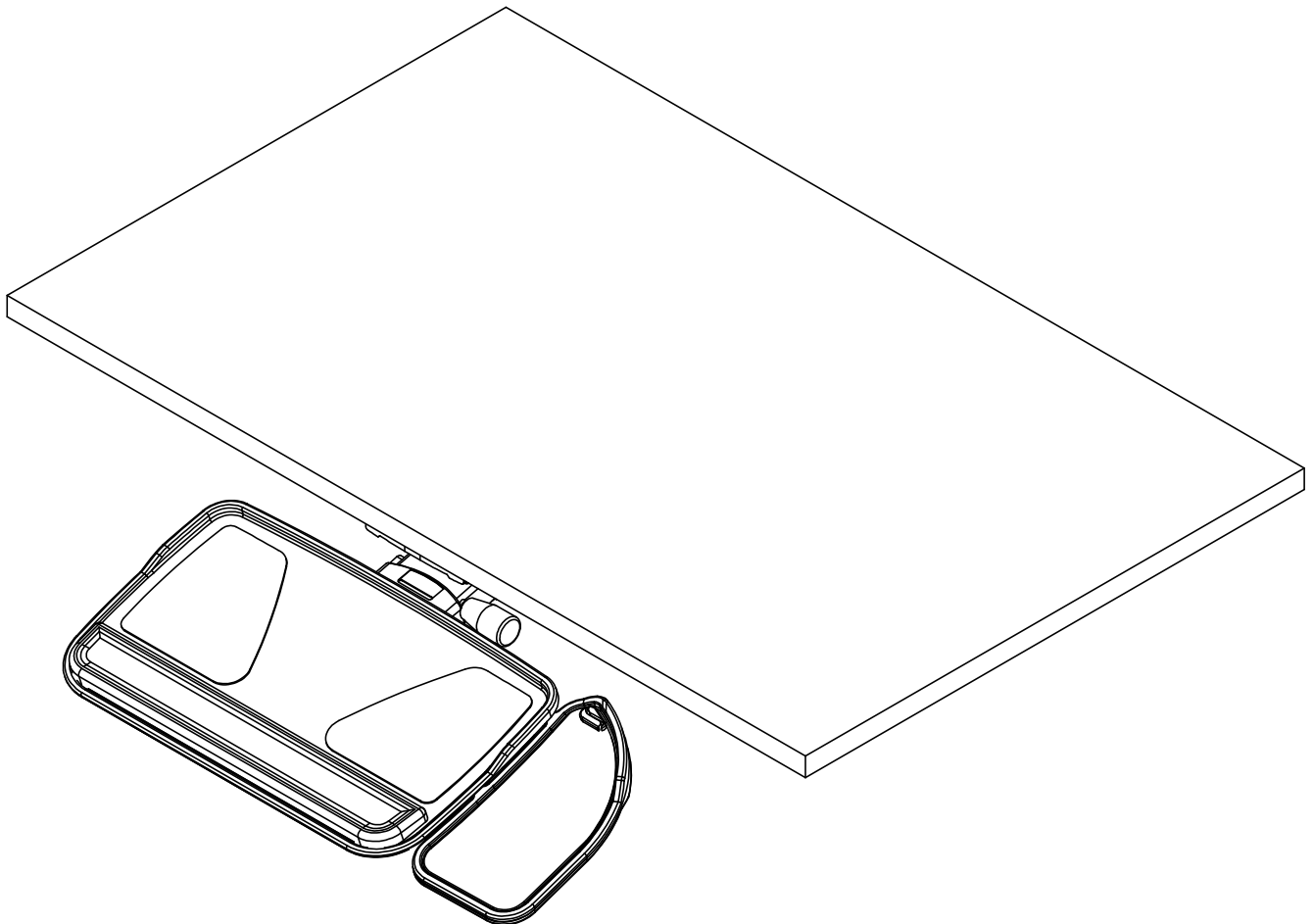

K&A Manufacturing
6703 Zinser Street
Schofield, WI 54476
Phone: 800.298.4351
Fax: 866.882.9475
www.raproducts.com
Version Dated: 4/2/15

Myriad Keyboard and Mouse Tray, Articulating Arm Installation Instructions



Read all the instructions before beginning.

Tools Required For Assembly:
 Power Driver W/Adjustable Torque
 #2 Phillips Head Driver Bit
 Tape Measure
 Square

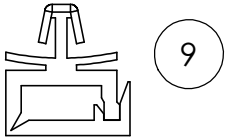
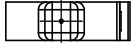

50363

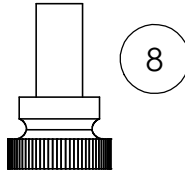
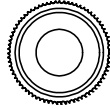

50016

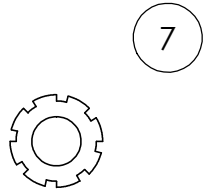
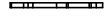

52490

Hardware Pack 50525 Drawn Actual Size



50232

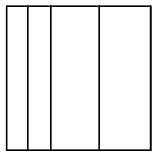
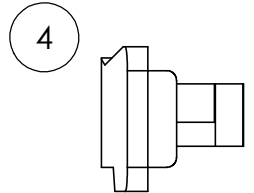

50299

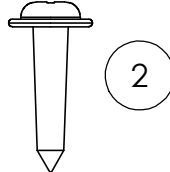
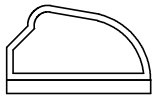

51708

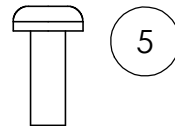

50200

Hardware Pack 50531 (Track Hardware) Drawn Actual Size

Use this for wire management as needed under the worksurface.

ITEM #	PART #	DESCRIPTION	QTY.
1	Varies	Track	1
2	51708	M5 x 18mm Sq/Ph/Washer Head Wood Screw	6
3	Varies	Articulating Arm	1
4	50232	Front Stop	1
5	50200	10-32 x 1/2 Self Tapping Machine Screw	2
6	MRD	Myriad Keyboard Tray	1
7	52490	M6 External Tooth Lock Washer	1
8	50016	1/4-20 Knurled Head Thumb Screw	1
9	50363	Wire Saddle Locking Top	2
10	MMT	Myriad Mouse Tray	1



K&A Manufacturing
6703 Zinser Street Schofield, WI 54476
Phone: 800.298.4351
Fax: 866.882.9475
www.raproducts.com

Step 1: Slide the articulating arm **3** out of the track **1** and set it aside. Determine the location to mount the articulating arm and track. Locate the track so the arm and tray can rotate left and right as much as you want them to rotate.

Step 2: Expose the glue dots on the top of the track **1** by pulling the paper strips off the track. See the top view of the track below. Position the track square with the front of the worksurface and back 3/8". Press the track firmly in place so the glue dots will hold the track onto the bottom of the worksurface.

Important Note: The worksurface material must be compatible with the screws provided. The worksurface must be at least 1" thick.

Step 3: Attach the track **1** to the worksurface using (6) wood screws **2** . Do not over-tighten the screws. Use a low torque setting on the power driver.

Step 4: Slide the articulating arm **3** back into the track **1** . Insert the front stop **4** into the front of the track. Attach it by using (2) self tapping machine screws **5** from the bottom up and into the track.

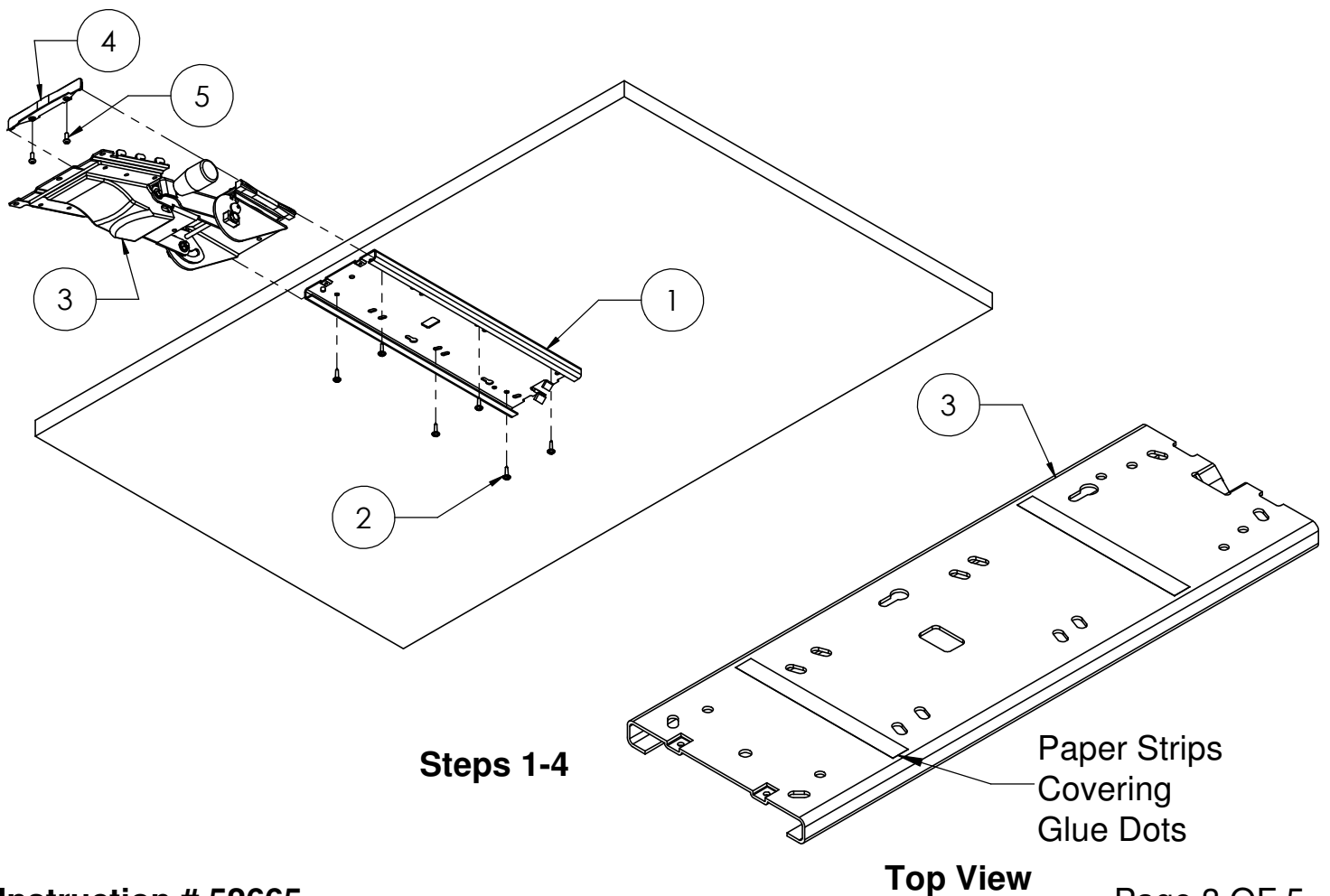

Step 5: Choose one of three keyboard tray 6 positions available. Insert the hooks on the articulating arm 3 into the set of slots corresponding to the position you desire. When the tray bottoms out, pull it forward as far as it will go. The hole at the front of the articulating arm

should align with one of the inserts in the bottom of the tray. place the lock washer 7 on the thumb screw 8 . Thread the thumb screw through the hole in the front of the arm into the insert in the tray. Fully tighten.

Step 6: Snap (2) wire saddles 9 into the holes at the back of the tray 6 .

Step 7: Choose one of four mouse tray 10 positions available as shown below. Also, see the Myriad features in the RightAngle ergonomic section of the catalog. There are (2) left hand and (2) right hand positions. Insert the square pegs on the side of the mouse tray into the square holes on the keyboard tray 6 corresponding to the position you desire. Slide the pegs into the holes until the buttons snap, locking the mouse tray in place. The keyboard and mouse tray positions can be changed at any time.

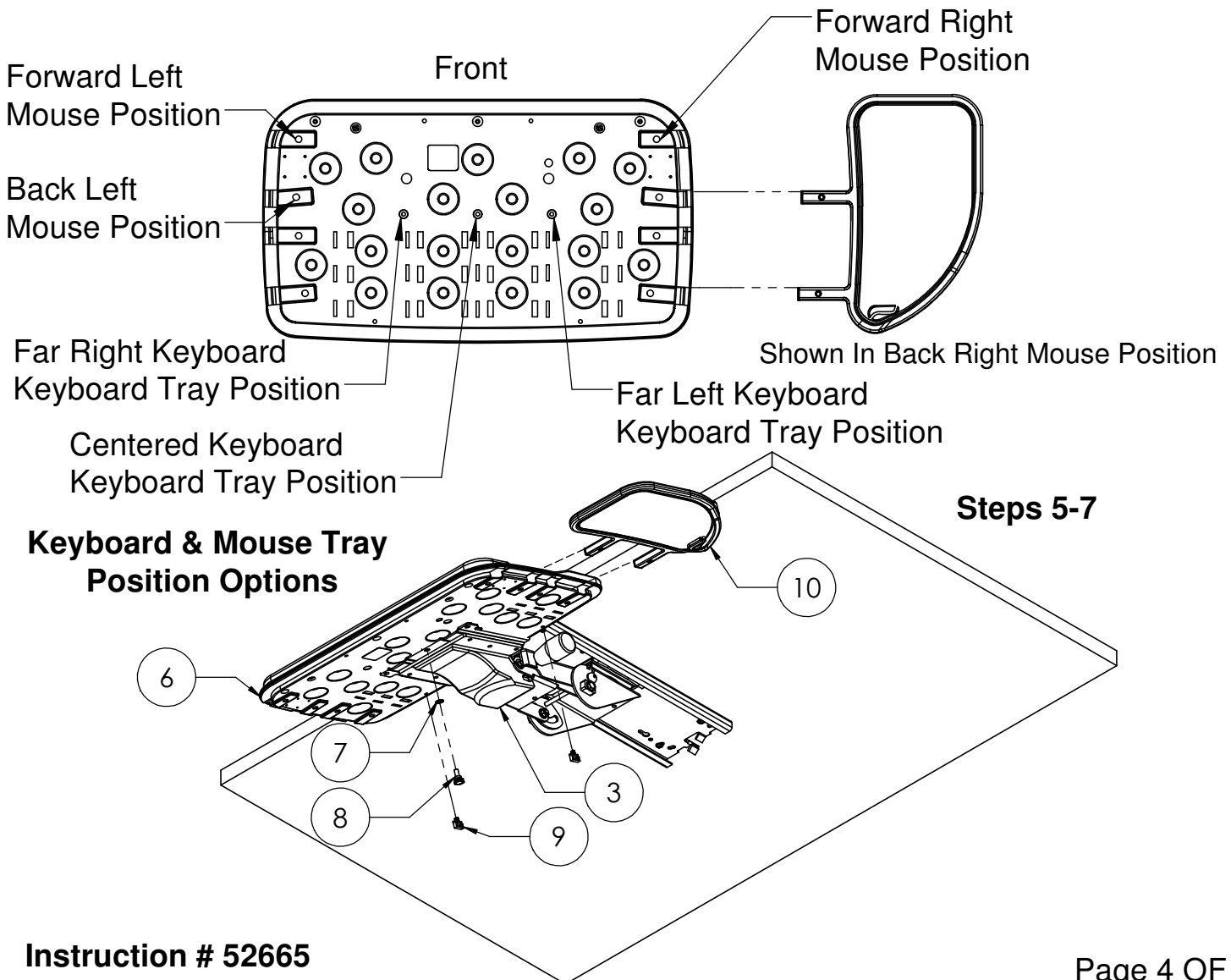



K&A Manufacturing
6703 Zinser Street Schofield, WI 54476
Phone: 800.298.4351
Fax: 866.882.9475
www.raproducts.com

Operation of the Myriad™ Keyboard And Articulating Arm Systems:

MFP21 Articulating Arm: For height adjustment, grasp the front and back edges of the tray. Tilt the tray toward the back and lift up or push down. Release the tray to lock it in place. To tilt the tray, turn the knob on the right hand side of the arm. The arm will slide forward and back in the track. It will also rotate left and right on the swivel with a moderate push.

MVS17 Articulating Arm: To operate the arm, loosen the knob on the right hand side. Tilt the tray up or down to the desired height. Retighten the knob. The arm will slide forward and back in the track. It will also rotate left and right on the swivel with a moderate push.

MFSS22 Articulating Arm: To raise the tray, lift up on the tray. It will lock in place. To lower the tray, tilt the tray back and push down. Release the tray to lock it in place. To tilt the tray, turn the knob on the right hand side of the arm. The arm will slide forward and back in the track. It will rotate left and right on the swivel with a moderate push.

MDA17 Articulating Arm: To raise or lower the tray, push the lever to the right and move the tray to the desired height. Push the lever to the left to lock the arm in place. To tilt the tray, pull out on the t-handle and tilt the tray to the desired angle. Release the handle to lock the tray in place. The arm will slide forward and back in the track. It will also rotate left and right on the swivel with a moderate push.

MFS17 Articulating Arm: To lower the tray, pull out on the ratchet lever and ratchet the tray to the desired position. To raise the tray, lift up on the front. To tilt the tray, loosen the ratchet lever. Tilt the tray to the desired angle and tighten the ratchet lever. The arm will slide forward and back in the track. It will also rotate left and right on the swivel with a moderate push.