

TOOLS REQUIRED FOR ASSEMBLY:

- CORDLESS DRILL
- #2 PHILLIPS HEAD DRIVER BIT
- 9mm WRENCH
- ADJUSTABLE SQUARE

CUSTOM CREATE A CORNER INSTALLATION INSTRUCTIONS:

STEP 1: PLACE THE TRACK **3** ON THE CREATE-A-CORNER **1** ALIGNING THE HOLES AT THE FRONT OF THE TRACK WITH THE HOLES IN THE CAC. ATTACH IT WITH (2) MACHINE SCREWS **5** AND (2) LOCK NUTS **2** THROUGH THE (2) OUTER HOLES AT THE FRONT OF THE TRACK.

STEP 2: SLIDE THE CAC ONTO THE WORKSURFACE WITH THE LARGER FLANGE AT THE TOP. SET IT AT A 45° ANGLE. ATTACH THE TRACK **3** TO THE WORKSURFACE WITH (4) TRACK SCREWS **7**. DO NOT OVERTIGHTEN THE SCREWS. USE A LOW TORQUE SETTING ON THE DRILL. PLACE THE REAR TRACK STOP **6** ON THE REMAINING TRACK SCREW. INSERT THE SCREW THROUGH THE CENTER HOLE AT THE BACK OF THE TRACK AND DRIVE IT INTO THE WORKSURFACE AND TIGHTEN.

STEP 3: ATTACH THE CAC **1** TO THE WORKSURFACE WITH (2) RECES DRIVE SCREWS **8** FROM THE BOTTOM UP.

STEP 4: SLIDE THE ARM (NOT SHOWN) INTO THE TRACK **3**. PLACE THE TRACK STOP **4** OVER THE FRONT OF THE TRACK ALIGNING THE HOLES IN THE TRACK STOP WITH THE HOLES IN THE TRACK AND CAC. INSERT (3) MACHINE SCREWS **5** THROUGH THE TRACK STOP, THE TRACK, AND THE CAC. THREAD (3) LOCK NUTS **2** ONTO THE MACHINE SCREWS AND TIGHTEN.

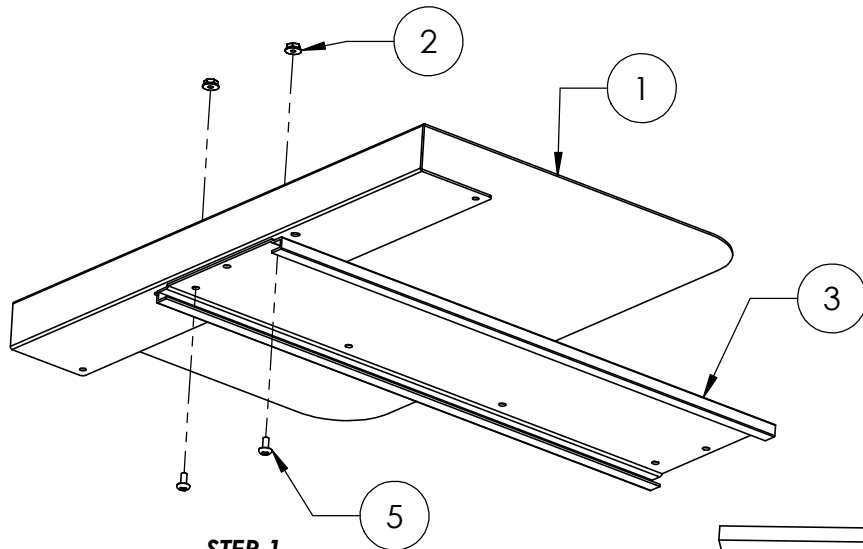

STEP 1

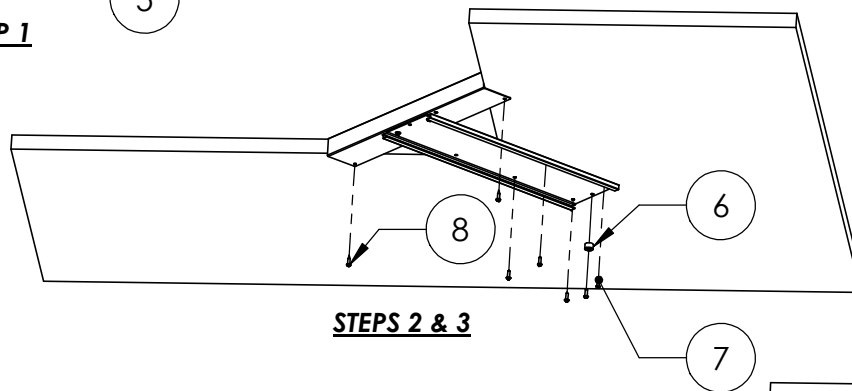

STEPS 2 & 3

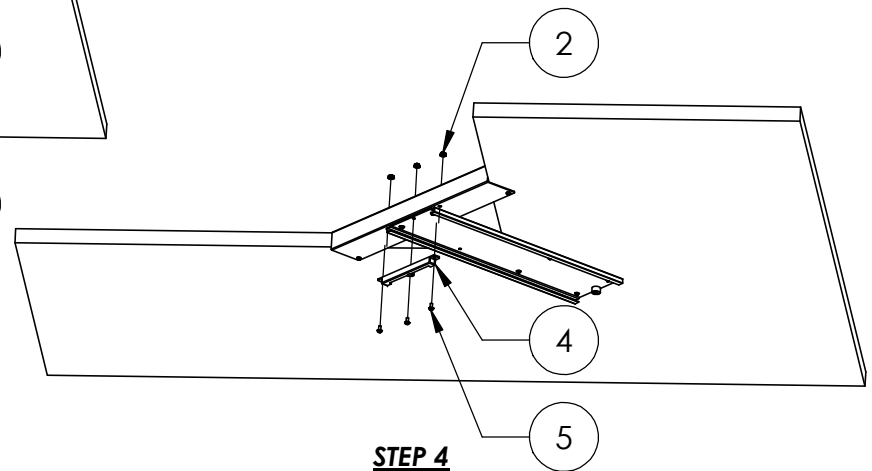

STEP 4

ITEM #	PART #	DESCRIPTION	QTY.
1	800568	CUSTOM 118CAC/1.250	1
2	50267	8-32 SERRATED FLANGE LOCK NUT	5
3	NA	CUSTOM TRACK	1
4	NA	CUSTOM TRACK STOP	1
5	52679	8-32 x 3/8 PHILLIPS TRUSS HEAD MACHINE SCREW	5
6	NA	CUSTOM REAR TRACK STOP	1
7	NA	CUSTOM TRACK SCREW	5
8	50072	8 x 3/4 PHILLIPS PAN HEAD RECES DRIVE SCREW	2