

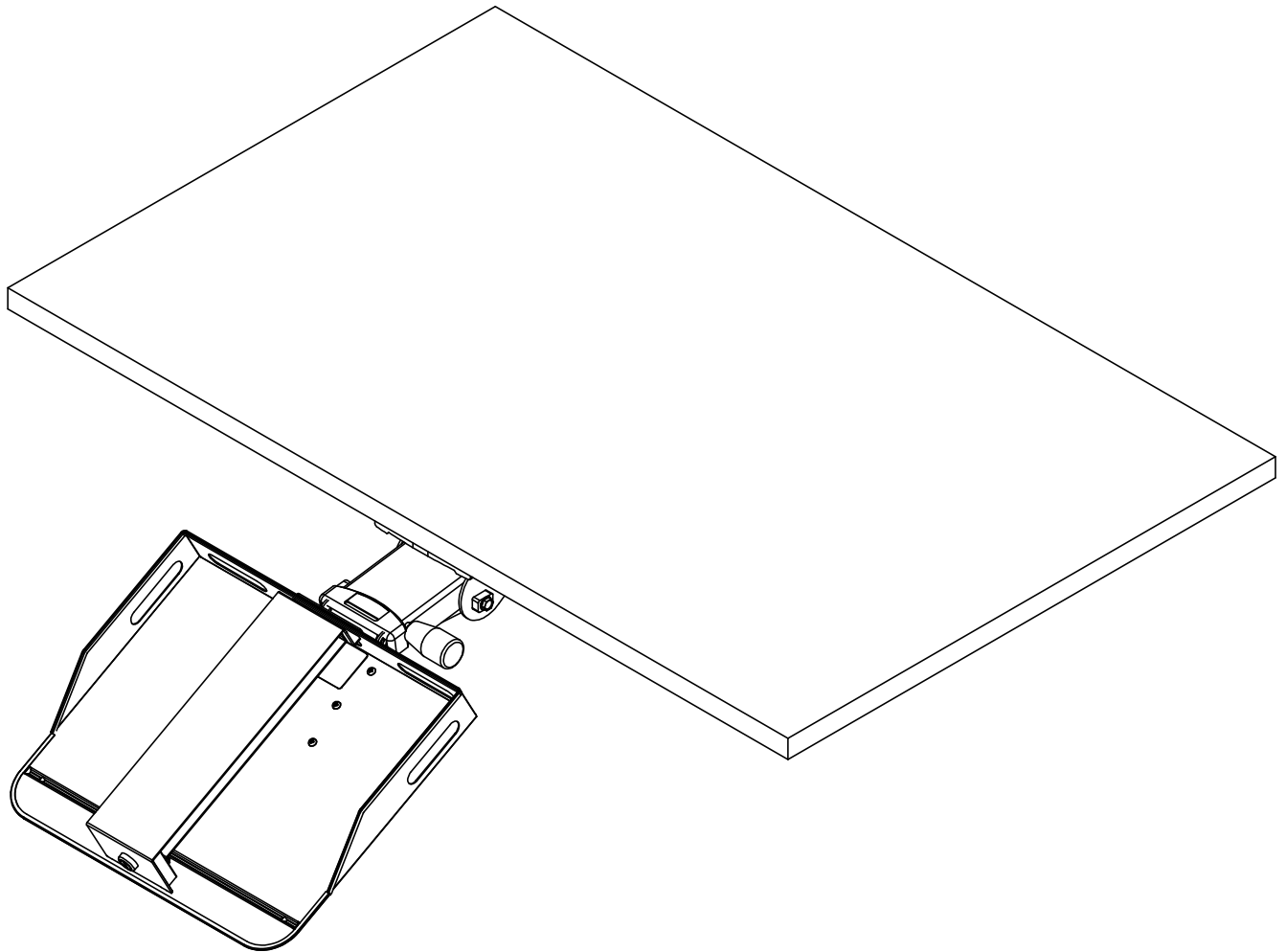

K&A Manufacturing
6703 Zinser Street
Schofield, WI 54476
Phone: 800.298.4351
Fax: 866.882.9475
www.raproducts.com
Version Dated: 6/11/15

415/417NSR Notebooksafe Tray Assembly & Operation Instructions



Read all the instructions before beginning.

Instruction # 50573

Hardware Pack # 50532 & 50531 (Track Hardware)



K&A Manufacturing
 6703 Zinser Street Schofield, WI 54476
 Phone: 800.298.4351
 Fax: 866.882.9475
 www.raproducts.com

Tools Required For Assembly:
 Power Driver W/Adjustable Torque
 #2 Phillips Head Driver Bit
 #2 Square Head Driver Bit
 Straight Driver Bit
 T-20 Torx Driver Bit
 7/16"/11 mm Wrench
 Tape Measure
 Square

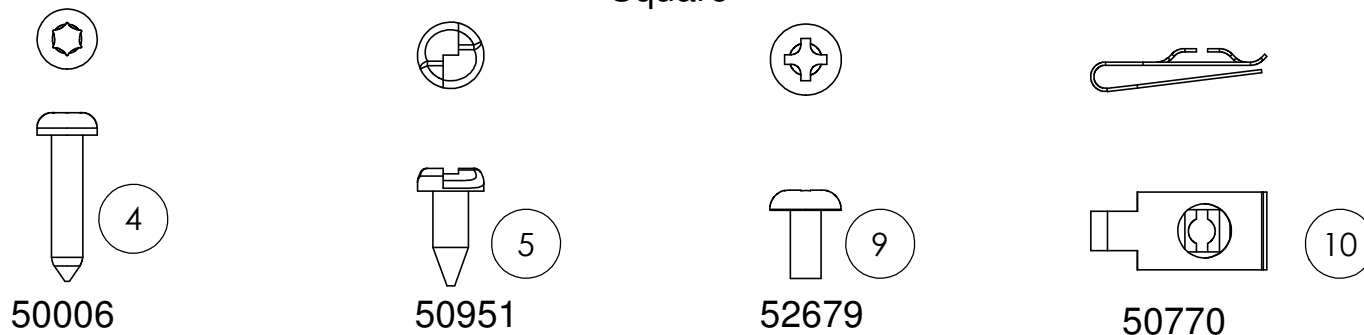

Hardware Pack 52375 Drawn Actual Size

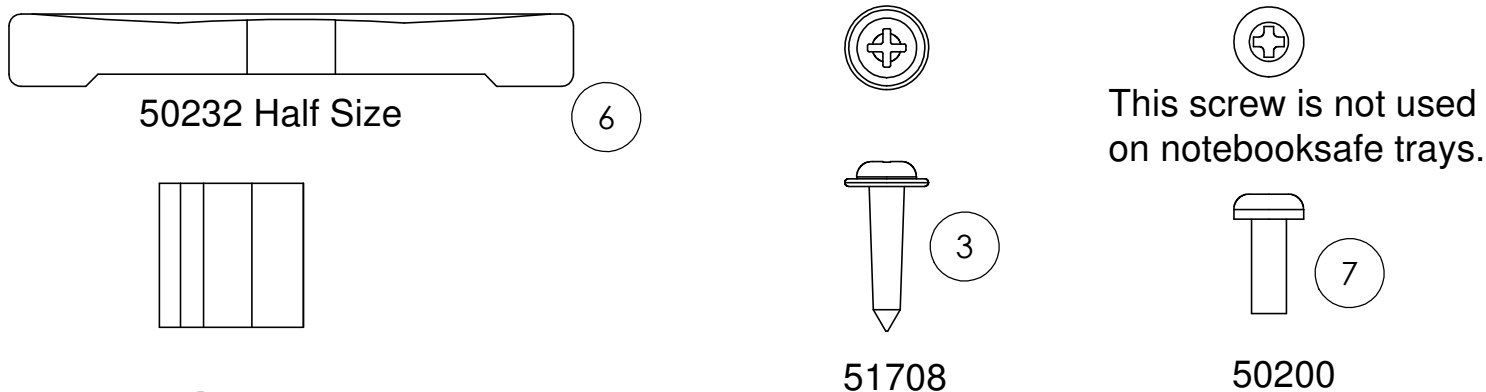

Hardware Pack 50531 (Track Hardware) Drawn Actual Size

50299
 Use this for wire management as needed under the worksurface.

ITEM #	PART #	DESCRIPTION	QTY.
1	Varies	Track Assembly	1
2	Varies	Articulating Arm	1
3	51708	M5 x 18mm Sq/Ph/Washer Head Wood Screw	6
4	50006	8-18 Tamper Resistant Sheet Metal Screw	2
5	50951	10x1/2 Round Head 1-way Sheet Metal Screw	2
6	50232	Front Stop	1
7	50200	10-32 x 1/2 Self Tapping Machine Screw	2
8	Varies	415/417NSR Notebooksafe Tray	1
9	52679	8-32 x 3/8 Phillips Truss Head Machine Screw	6
10	50770	8-32 x 7/8 U-Nut	6
11	800499	Lockbar Complete Assembly	1

Step 1: Slide the articulating arm **2** out of the track **1** and set it aside. Determine the location to mount the articulating arm and track. Locate the track so the arm can rotate left and right as much as you want them to rotate.

Step 2: Expose the glue dots on the top of the track **1** by pulling the paper strips off the track. See the top view of the track below. Position the track square with the front of the worksurface and back 3/8". Press the track firmly in place so the glue dots will hold the track onto the bottom of the worksurface.

Important Note: The worksurface material must be compatible with the screws provided. The worksurface must be at least 1" thick.

Step 3: Attach the track **1** to the worksurface using (6) wood screws **3**. Do not over-tighten the screws. Use a low torque setting on the power driver.

Step 4: Slide the articulating arm **2** back into the track **1**. Insert the front stop **6** into the front of the track. Attach it by using (2) 1-way sheet metal screws **5** from the bottom up and into the track.

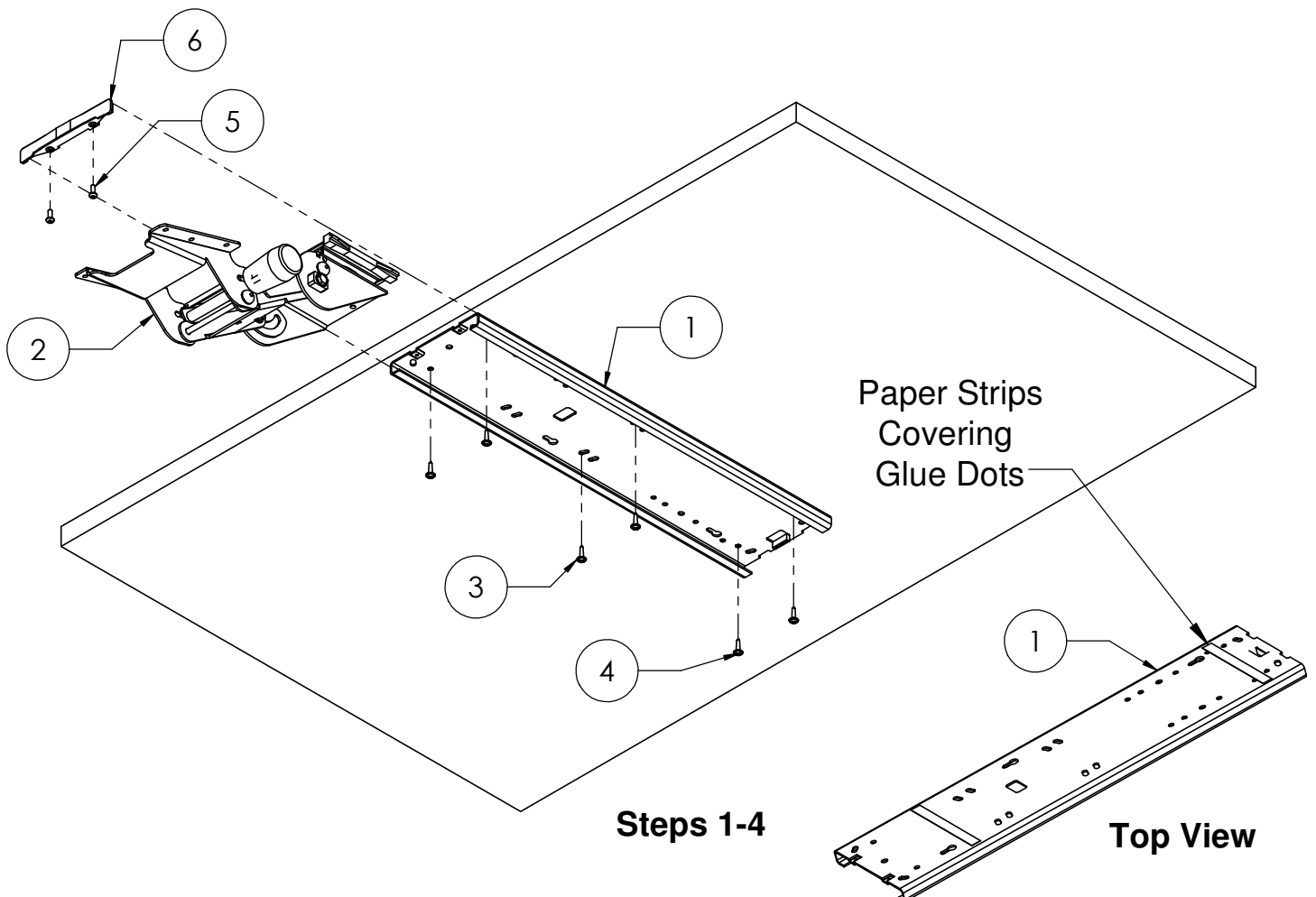

Step 5: Align the holes in the bottom of the tray **8** with the holes in the articulating arm **2** . Mark the (6) holes you will use and set the tray aside.

Step 6: Slide (6) u-nuts **10** onto the arm **2** aligning the marked holes in the tray with the holes in the u-nuts. See the detail below.

Step 7: Place the notebooksafe tray **8** on the articulating arm **2** aligning the holes in the tray with the holes in the u-nuts. Insert (6) machine screws **9** through the holes in the tray and thread them into the u-nuts **10** . Fully tighten.

Step 8: Adjust the tray to the desired position. See Page 6 of 6.

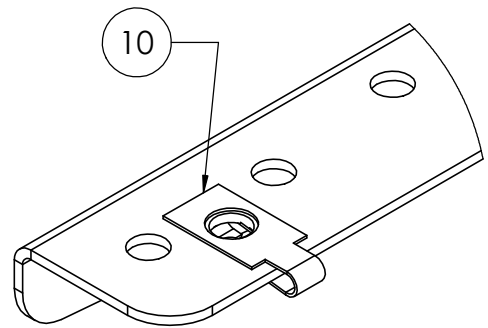
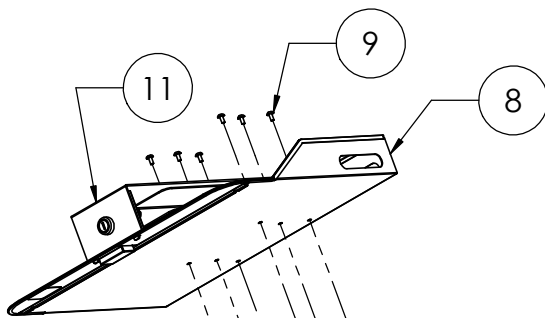

Installation of u-nuts. Center u-nut holes on the marked holes on the arm.

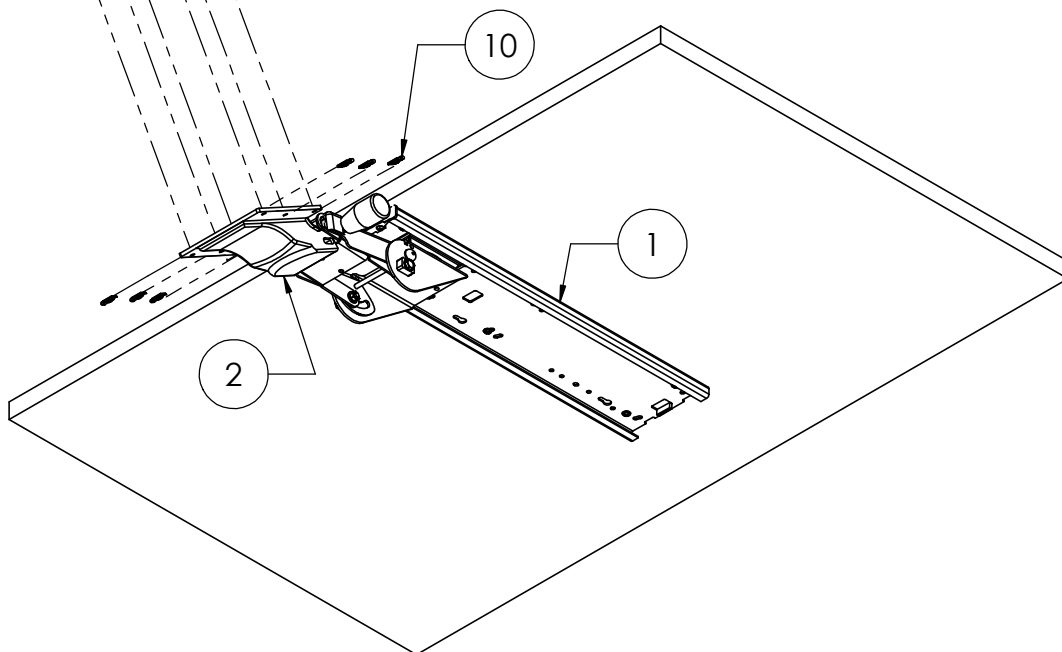

Operation And Adjustment Of The Lockbar Assembly:

To remove the lockbar, turn the key. Tilt the assembly up and pull it forward to disengage the tab from the slot.

You may need to adjust the lockbar assembly for the thickness of your notebook computer. There are three sets of slots and three sets of screw holes on the lockbar for spacer adjustment. Remove the (2) sheet metal screws holding the spacer to the lockbar. Set the spacer at the height needed and replace the screws. The spacer can also be removed completely from the lockbar assembly for the deepest setting.

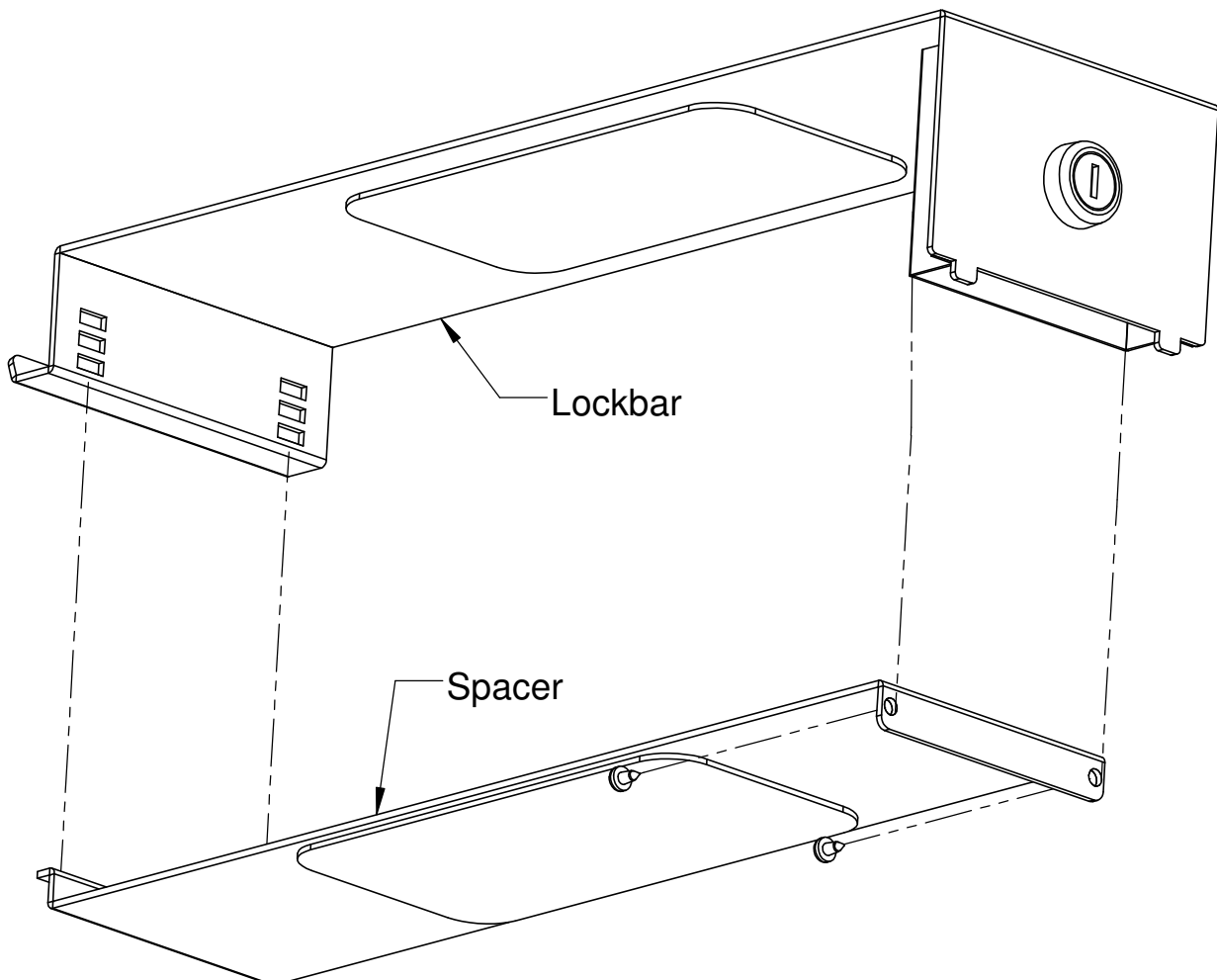



K&A Manufacturing
6703 Zinser Street Schofield, WI 54476
Phone: 800.298.4351
Fax: 866.882.9475
www.raproducts.com

Operation of the 415/417 Notebooksafe Tray And Articulating Arm Systems:

NFP23/S Articulating Arm: For height adjustment, grasp the front and back edges of the tray. Tilt the tray toward the back and lift up or push down. Release the tray to lock it in place. To tilt the tray, turn the knob on the right hand side of the arm. The arm will slide forward and back in the track. It will also rotate left and right on the swivel with a moderate push.

NVS23/S Articulating Arm: To operate the arm, loosen the knob on the right hand side. Tilt the tray up or down to the desired height. Retighten the knob. The arm will slide forward and back in the track. It will also rotate left and right on the swivel with a moderate push.

NFSS26/S Articulating Arm: To raise the tray, lift up on the tray. It will lock in place. To lower the tray, tilt the tray back and push down. Release the tray to lock it in place. To tilt the tray, turn the knob on the right hand side of the arm. The arm will slide forward and back in the track. It will rotate left and right on the swivel with a moderate push.

NDA23/S Articulating Arm: To raise or lower the tray, push the lever to the right and move the tray to the desired height. Push the lever to the left to lock the arm in place. To tilt the tray, pull out on the t-handle and tilt the tray to the desired angle. Release the handle to lock the tray in place. The arm will slide forward and back in the track. It will also rotate left and right on the swivel with a moderate push.

NFS26/S Articulating Arm: To lower the tray, pull out on the ratchet lever and ratchet the tray to the desired position. To raise the tray, lift up on the front. To tilt the tray, loosen the ratchet lever. Tilt the tray to the desired angle and tighten the ratchet lever. The arm will slide forward and back in the track. It will also rotate left and right on the swivel with a moderate push.